

Infrared sensor instruction manual

PRO RANGE-KD200-M-NC

(Relay normally closed output)

table of Contents

1st. Overview.....	2
2nd.Product Features.....	2
3rd.Technical Parameters.....	2
4th. wiring diagram of various models.....	3
5th. Installation method.....	4
6th. Sensing distance adjustment.....	4
7th. Product size and physical map.....	5
8th.Sensing range and angular displacement.....	6
9th.Product warranty terms and instructions.....	6
10th. Manual version.....	7



1st. Overview

PRO RANGE-KD200-M-NC is an intelligent non-contact sensor switch. The sensor uses the principle of diffuse reflection of infrared light on the object. When a person or object enters the sensing range directly in front of the sensor, the sensor immediately judges that there is a sensor, thereby controlling the output signal; After the person or object leaves the sensing range, it is immediately judged that there is no sensing, and the output signal is released to achieve the purpose of intelligent control.

2nd. Product Features

Can be used for: security alarm, sensor light, smart trash can, mirror light box, advertising machine, shoe polisher, sensor water dispenser, vending machine, faucet, shower head and other functions. It integrates infrared emission, reception, and intelligent control, with stable and reliable performance.

3rd. Technical Parameters

Project name	Parameters
Operating Voltage	DC 5V~24V
Signal output method	Relay normally closed 5V -24V output
Sensing distance	The distance is adjustable from 0.3cm to 180cm (the sensing distance and the obstacle color has a certain error, light color is far, dark color is close)
Sensing angle	30-40° cone angle
Induction method	Proactive approach
Quiescent Current	<3.5 mA
Load current	<1A
Working temperature	-20 ~ 85°C
storage temperature	-20 ~ 85°C
Line length	30cm (±10MM) (Bulk can be customized)
Material	PC-V0 fireproof material
Waterproof performance	IP67
Safety standard certification	CE
Environmental certification	ROHS-2.0

4th. wiring diagram of various models

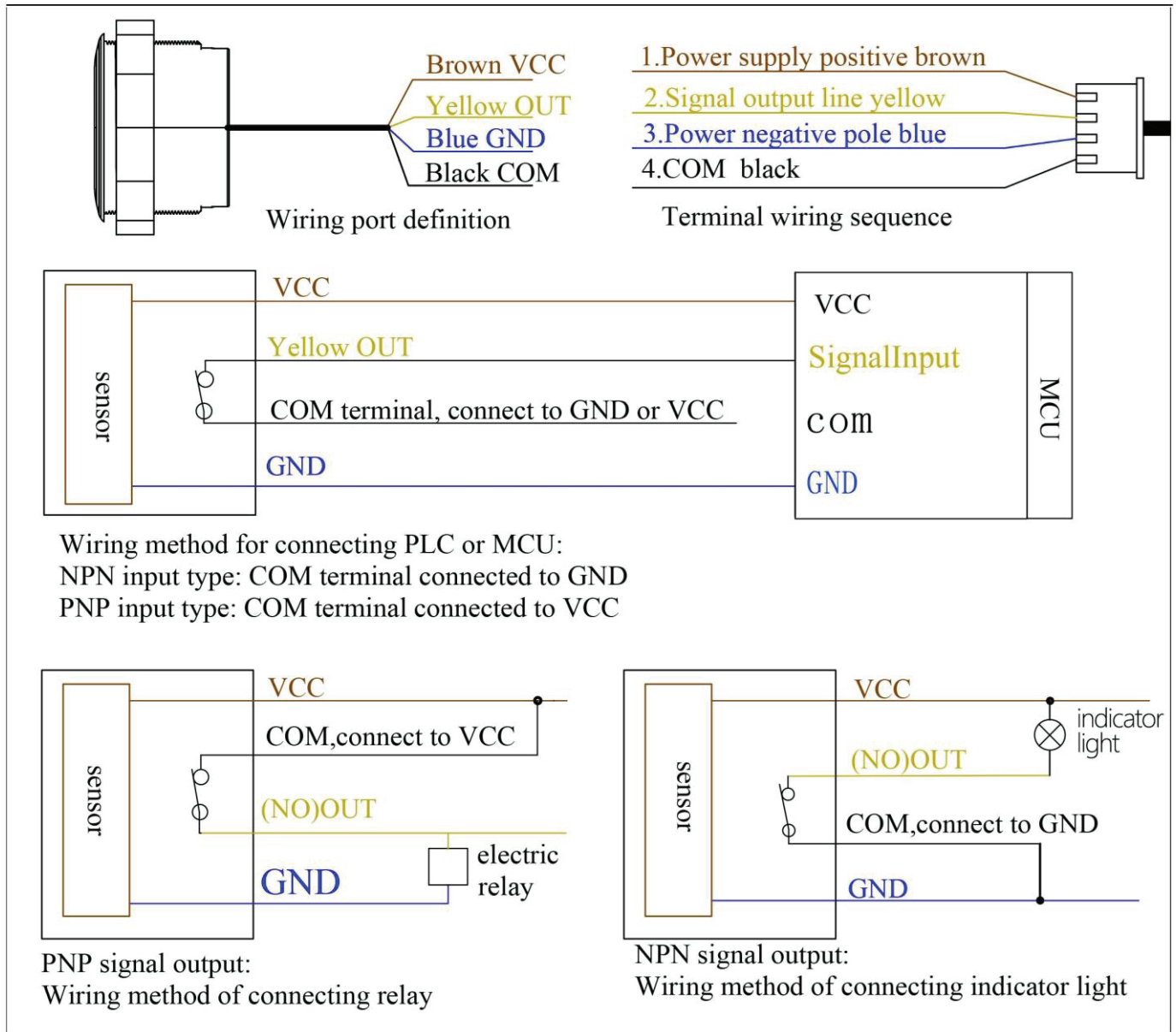

Working principle of relay NC point output:

1. When the black wire is connected to VCC:

When object is sensed, the relay is closed and the relay NC point is disconnected;

When no object is sensed, the relay is disconnected, the NC point of the relay is turned on, and the VCC voltage is output.

2. When the black wire is connected to GND:

When object is sensed, the relay closes, and the relay NC point opens;

When no object is sensed, the relay is disconnected, the relay NC point is turned on, and the GND voltage is output.

5th. Installation method

Open a hole on the panel where the sensor needs to be installed. The hole diameter is 28mm. Install the sensor into the hole from the front of the panel and tighten the nut behind the sensor.

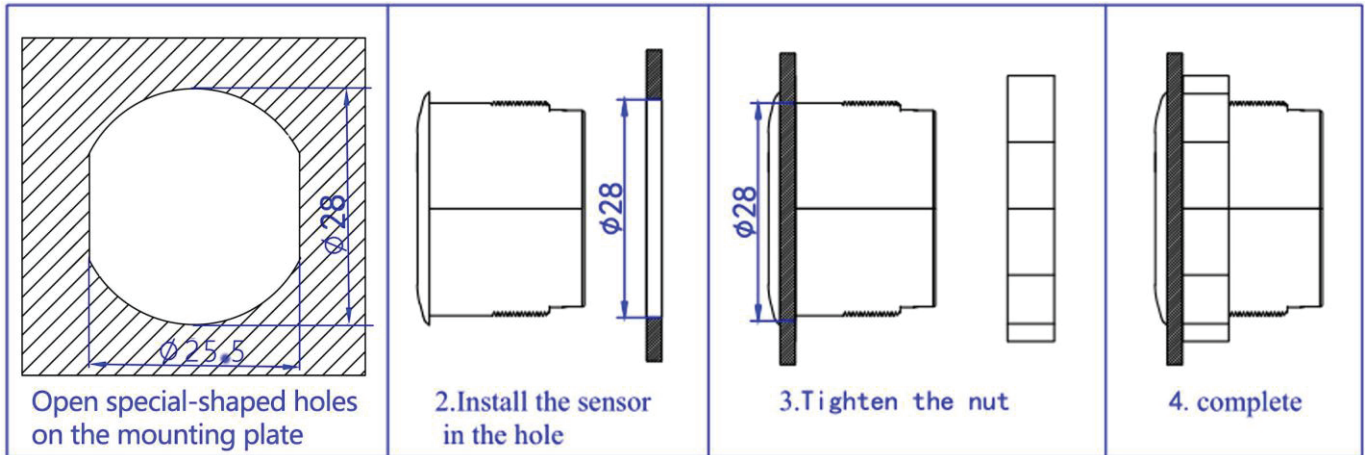

6th. Sensing distance adjustment

The sensor is energized and working normally. Place approximately 80x60cm kraft cardboard in front of the sensor less than or equal to 80cm. The steps for adjusting the sensing distance are as follows

Enter the distance adjustment mode: long press the light touch button, when the red LED indicator flashes, enter the automatic distance adjustment mode.

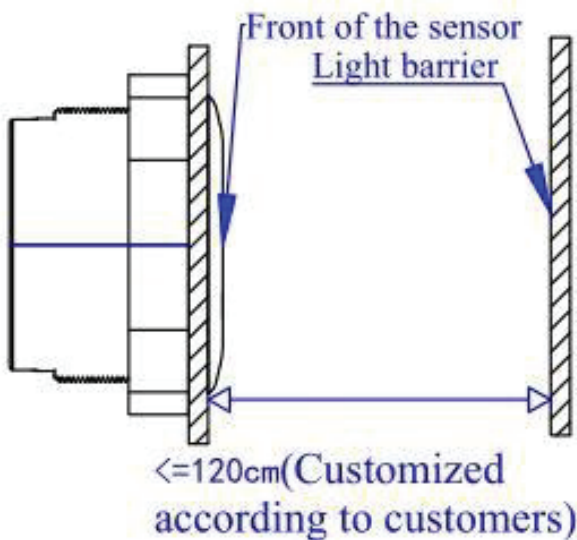

Sensing distance adjustment process

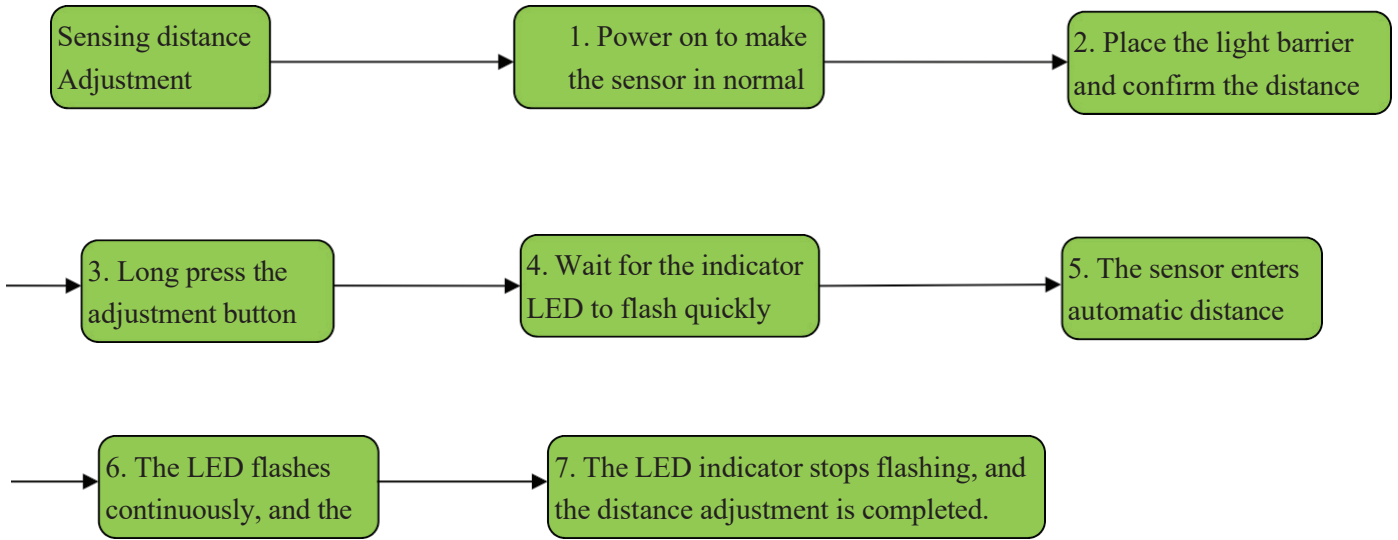

7th. Product size and physical map



Thread pitch is M27.5*1.5mm.

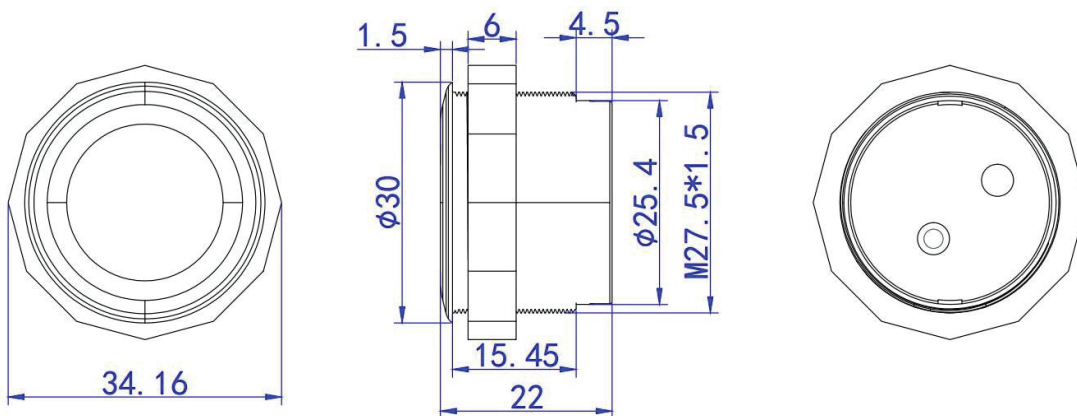

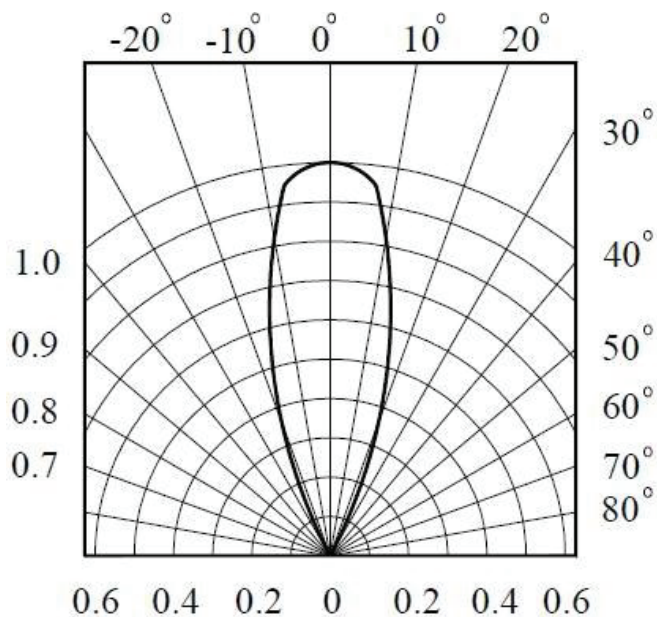

9th.Product warranty terms and instructions

(A). Warranty service

1. Warranty period maintenance: from the date of purchase, the product host has a one-year free warranty. The company has the right to decide to repair or replace the faulty part. If it is replaced, the replacement part may be a new device or a repair product of the same category, function, and quality. The replaced faulty part belongs to the company; the product Resale and repair do not affect the warranty period. Products that have been repaired or replaced continue to enjoy the original remaining warranty period service. If the warranty period is less than three months after the repair, the repaired or replaced part shall be shipped from the date of delivery Warranty for three months; all products of the company are guaranteed for repair.

2. Loss upon arrival (DOA) replacement: From the day of purchase, you can enjoy a free replacement service within 7 days. Products with the following problems are defined as DOA equipment: the packing and packing list do not match after the first unpacking of the product; some or all of the components cannot be used normally after the first unpacking of the product (surface scratches or other things that do not affect the function of the device) Defects are not included); other hardware failures identified by our company's engineers remotely or locally.

(B). Applicable limitations of warranty

For the following situations, the company does not assume warranty responsibility:

1. The product is out of warranty; the surface of the product is fragile and damaged; the appearance of the product is seriously damaged, installation/use in abnormal environment, unauthorized disassembly and repair/modification, external power supply damage and other abnormal damage.
2. Damage caused by incorrect installation and use of the product by the user not following the requirements of the

manual;

3. Damage caused by natural disasters and human negligence (fire, lightning, flooding, impact, etc.).

(C) . Accessories and consumables are not covered by the warranty.

(D) . Non-free warranty service

Within two years of product purchase, for non-warranty product (including components) failures and damages, you can choose paid maintenance services (free labor costs), and we will charge the transportation cost of repairing parts and accessories according to the actual situation.

(E). Ways to obtain warranty service

It is recommended that you contact the dealer who purchased this product to obtain the warranty service. For the warranty, please present a valid warranty card (the dealer's stamp is required to take effect) or the purchase invoice/receipt: if you can't show it, the product's free warranty period 12 months from the product shipment date, and the latest DOA application deadline is 7 days from the product shipment date.

(F). Statement

1. The copyright of this manual belongs to Shenzhen Pro Range Technology Co., Ltd. (Pro Range) and its authorized licensors. Shenzhen Pro Range Technology Co., Ltd. (Pro Range) reserves all rights.

2. Without the written permission of the company, no unit or individual may excerpt or copy part or all of the contents of this manual, and shall not spread it in any form.

3. The customer recognizes that the purpose of the design and production of the company's products does not involve use in products related to life support or other systems or products used in other dangerous activities or environments. Personal injury or death, property or environmental damage due to product failure (collectively referred to as high-risk activities). The company's products are artificially used in high-risk activities, and the company does not guarantee it and is not liable to customers or third parties.

4. Due to product version upgrades or other reasons, the contents of this manual may change. Pro Range reserves the right to modify the contents of this manual without any notice or prompt. This manual is only used as a guide. Pro Range makes every effort to provide accurate information in this manual. However, Pro Range does not guarantee that the contents of the manual are completely free of errors. All statements, information and suggestions in this manual do not constitute any express or Implied guarantee.

5. Not all models are available in all countries/regions

Please keep this manual properly. Before using the product, please read this manual carefully. When using the product, please be sure to operate in accordance with this manual. The company is not responsible for injuries and accidents caused by operations that do not follow this manual.

(G). Environmental protection This product meets the design requirements for environmental protection. The storage, use and disposal should comply with relevant national laws and regulations. Seek to proceed.

10th. Manual version

Version	Release date
V19	March 15, 2023