



MS58-1414D20M4
MoreSense 5.8G Radar Sensor Module
User Manual V1.1

Revision History

Revision	Description	Release Date
V1.0	MS58-1414D20M4 User Manual Initial Version	2021-5-1
V1.1	Optimized Product Description's Structure	2021-11-12

Proprietary Statement:

Shenzhen MoreSense Technology Co., Ltd.

All Rights Reserved

Copyright © 2021 by MoreSense

Catalog

1 Product Description	1
2 Product Features	2
3 Key Application	3
4 Module Parameter	4
5 Pin Definition	5
6 Module Dimension	5
7 Name Rules	6
8 Operation Guideline	7
8.1 Module Out RAM Timings	7
8.2 Induction Range	7
9 Precautions	8
10 Customation	9
11 Hardware Typical Application	9
12 Package Information	10
12.1 Recommended Relow Soldering Profile	10
12.2 Instruction	11
12.3 Package Method	11

1 Product Description

MS58-1414D20M4 is a miniaturized 5.8G radar sensor module launched by MoreSense. This module uses high-performance radar sensors combined with miniaturized planar antennas to achieve a size of 14.5x14.5mm while ensuring the performance of the sensor.

The sensor can detect that if there have the moving objects in the region by frequent difference between the transmit and receive signals (Doppler Principle) or high-frequency electromagnetic waves.

The sensor is not affected by ambient temperature, humidity, airflow, dust, noise, brightness and so on. With a built-in multi-filter algorithm, the module has a strong anti-jamming capability and its signal can penetrate glass, axle and other non-metallic materials. The sensor can be used to detect various scenes of human being or moving target sensing, including including Smart Home, Smart Doorbell, Smart Door Lock, etc. It is especially suitable for low-power battery-powered scenes such as night lights, solar street lights and wireless cameras.

The module comes with its own default parameters and can be flexibly modified by serial port instructions or PC upper computer.



2 Product Features

- a. Working Frequency Band:5.8G ISM Frequency Band;
- b. Microwave sensor based on Doppler effect;
- c. Sensing distance and delay time can be adjusted flexibly according to different application;
- d. Using mature CMOS technology to achieve fully integration of ultra-cost-effective;
- e. The chip has a built-in LDO that supports wide-voltage power supply;
- f. Support standard UART, I2C interface,can be interconnected with other main control or sensors;
- g. With self-calibration function, it is not affected by external interference and supports dense distribution;
- h. Meet certification standards such as FCC, RED, CE, and ETL;

3 Key Application

- Smart Home: Wall Switch; Refrigerator...
- Induction of Moving Targets: Smart Door Locks; Smart Doorbells...
- Intelligent Lighting: Corridor Lights; Mirror Lights; Disinfection Lights; Miner's Lamps...
- Security and Smart Surveillance: Cameras...

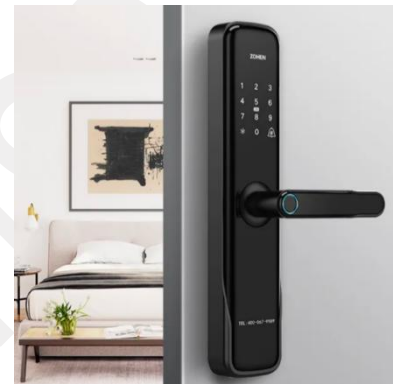

4 Module Parameter

Type	Parameter	Value
RF Parameter	Certification Standards	FCC/CE/SRRC/RoHS
	Frequency Range	5.725GHz-5.875GHz
	Transmit Power	-4dBm
	Antenna	Built-in;Flat Antenna
Hardware Parameter	Data Interface	GPIO/UART
	Operating Voltage	DC4.5-5.5V (or DC3.3V)
	Operating Current	20mA(Typical Value)
	Operating Temperature	-40°C- 85°C
	Storage Temperature	-40°C- 150°C
	Humidity	<85%
	Dimension	14.5mm x 14.5mm
Default Parameter	Power-On Self-Test Time	2s
	Sensing Output Level	5V(or 3.3V)
	Silent Output Level	0V
	Sensing Output Time	2s
	Inducting Distance	About 8m
	Customizing the Largest Sensing Distance	10m
	Max. Induction Radius with Hanging Height 3m	4-5m
	Setting Parameter Method	UART or IO

5 Pin Definition

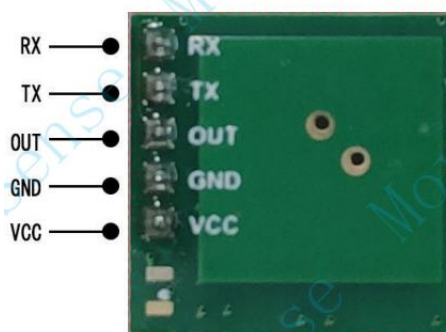
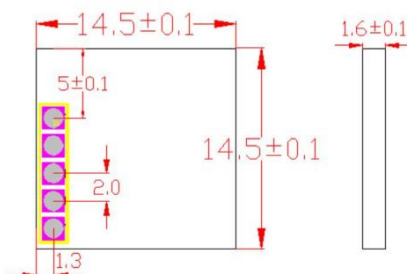

Table.1 MS58-1414D20M4 Pin Function Definition

Pin	Name	Type	Description
1	VCC		Power Supply
2	GND		Ground
3	OUT	I/O	Sensing Signal Output
4	TX	I	UART Transmitting
5	RX	O	UART Receiving

I:Input O:Out

6 Module Dimension



Unit: Millimeter (mm)

7 Name Rules

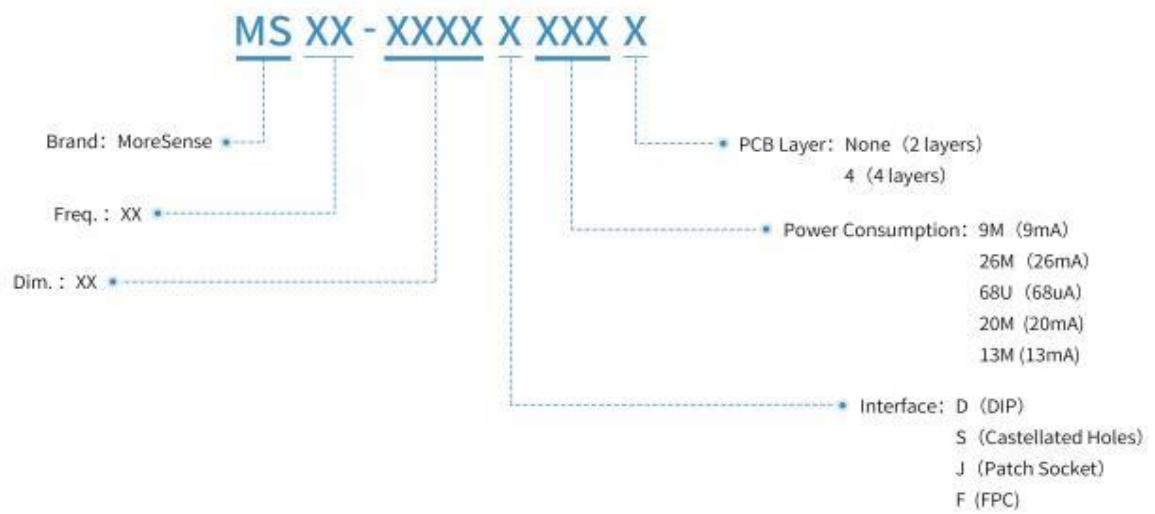

④Interface

D



J



S

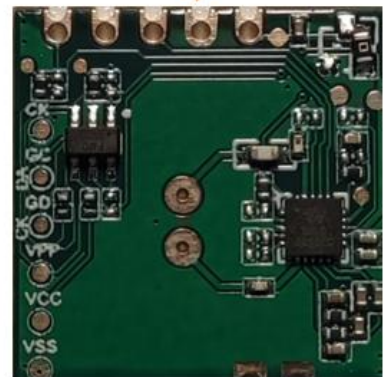

8 Operation Guideline

8.1 Module OUT RAM Timings

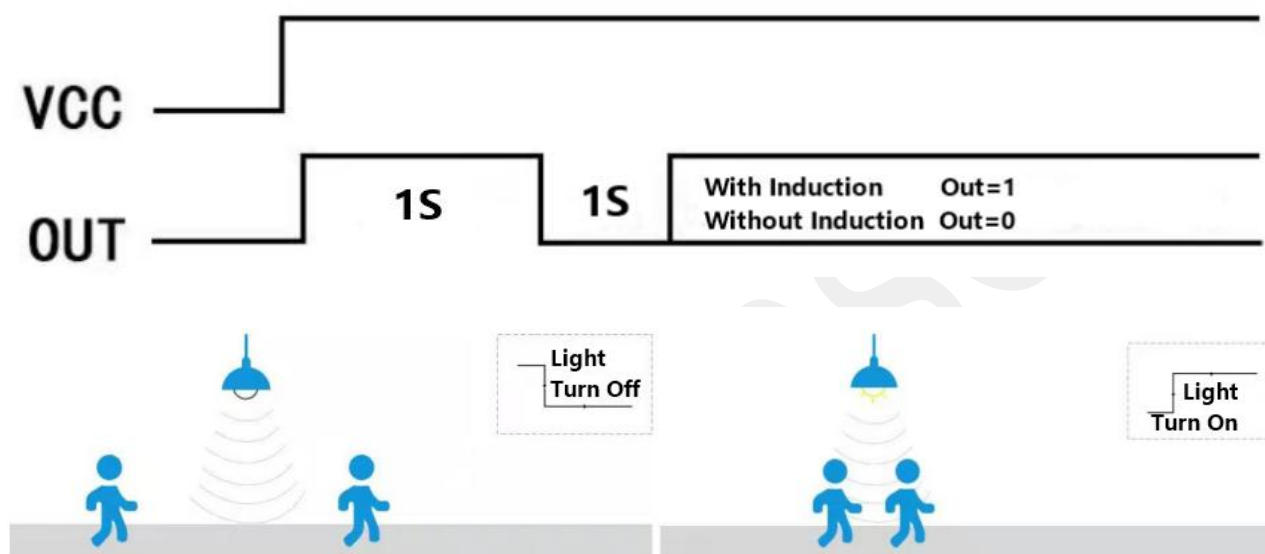

8.2 Induction Range

The sensing angle is 120°. The sensing sensitivity of radar sensor can be configured by MCU. The actual sensing distance can be adjusted according to the needs. The above is the schematic diagram of radar detection range in case of high hanging. If the sensitivity is set higher, the detection range will be correspondingly larger. In the figure, the dark area is the high sensitivity area that the object can be fully detected, while the light area is the low sensitivity area that the object can be detected basically. The actual product structure and assembling environment also affect the distance and angle of radar detection.

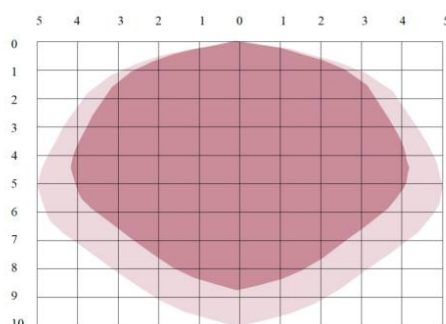

9 Precautions



Precautions

Try to avoid placing the radar antenna in the direction of large metal equipment or pipes,etc.

The front of the antenna should be installed without a metal shell or components to avoid shielding the signal.

The power supply driving capability of the radar module needs to be greater than 50mA,otherwise the sensor will be abnormally operating.

The power frequency will interfere with the radar signals.During installation,it should avoid forwarding the AC drive power supply,staying away from AC power lines,rectifier bridges and other lines.

Covers such as glass,acrylic,or plastic are allowed,but there should be a proper clearance area in front of the antenna,and a minimum spacing of 5mm or more is recommended.

During installing multiple radar modules,please try to ensure that the antennas of each radar module are parallel to each other,avoiding positive irradiation between the antennas,and to maintain more than 1 m of space between the modules.

10 Customization

Power Supply Voltage	Sensing Out Method	Setting Parameter	Supplement
<input type="checkbox"/> 3.3V	<input checked="" type="checkbox"/> IO Out (Reverse Supported)	<input type="checkbox"/> IO Setting Para.	<input checked="" type="checkbox"/> Light Sensor
<input checked="" type="checkbox"/> 5V	<input checked="" type="checkbox"/> UART	<input checked="" type="checkbox"/> UART	<input type="checkbox"/> Power Management Function
<input type="checkbox"/> 12V	<input checked="" type="checkbox"/> PWM	<input type="checkbox"/> IIC	—
<input type="checkbox"/> 24V	—	—	—

: Supporting : Supported

11 Hardware Typical Application

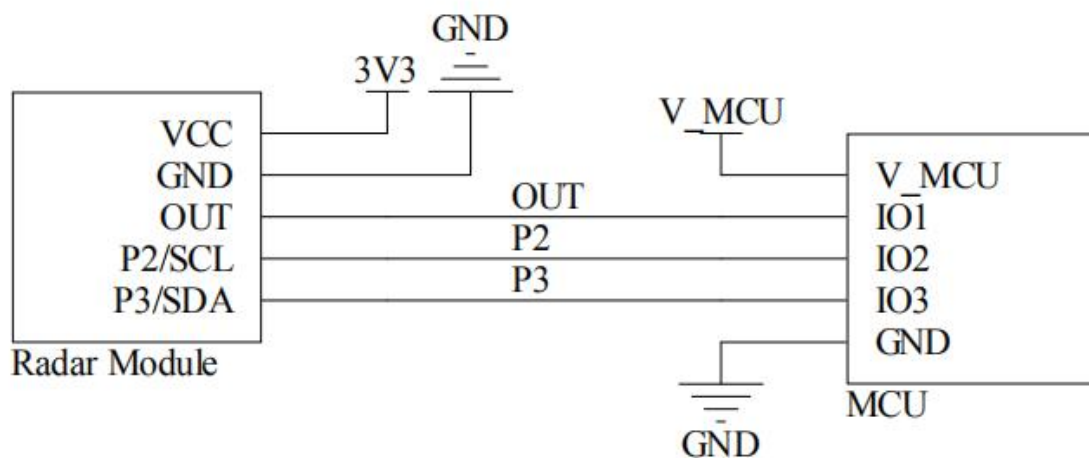

12 Package Information

12.1 Recommended Reflow Soldering Profile

Figure 1. Thermal Reflow Profile

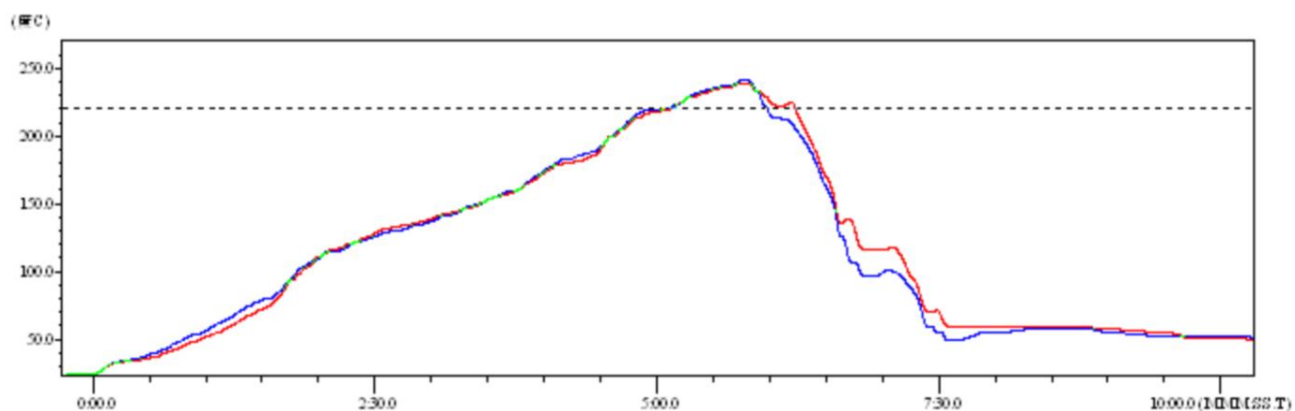

Table 1. Reflow Data

No.	Program	Temp. (°C)	Time(S)
1	Refluxing Time	Above 220°C	35~55S
2	Peak Temp.	Highest 260°C	

Note:

- 1.It is recommended to use a nitrogen reflux furnace;
- 2.The oxygen content is less than 300ppm.

12.2 Instruction

A. Sealed storage period:12 months in an environment with a temperature of less than 30°C and a relative humidity of less than 60%.

B.Be re-baked before using if the window time exceeds 168 hours after unpacking.

C. Recommended to use nitrogen filling method for baking.

D. Recommended to use nitrogen filling method.

E, Baking and rework requirements for this model:125±5°C, 24 hours.

F. Recommended storage conditions $\leq 10\%$,relative humidity under vacuum packaging.

G.If the SMT process requires to pass twice reflow ovens:

① TOP Surface② BOT Surface

Situation 1:The radar module is designed on the TOP surface of the customer's PCB.The the TOP surface needs to be baked when the TOP surface has not been produced after the BOT surface has been finished 168 hours (window time).

Situation 2;The radar module is designed on the BOT side of the customer's PCB and follows the normal baking rules.

Note:The window time means 168 hours from the end of the last baking to the beginning of the next reflow.

12.3 MS58-1414D20M4 Package Method

Blister Packaging(Insulation)

