

## Instructions for infrared sensor

### PRO RANGE-KE200-PUB

#### catalogue

1. summary.....	2
2. application environment .....	2
3. Product selection (this product has various specifications as follows).....	2
4. technical parameter .....	2
5. The wiring principle .....	4
6. Installation method.....	7
7. Induction distance adjustment .....	8
8. dimensions and physical drawings.....	9
9. induction range and angular displacement.....	9
10. Product warranty terms and description.....	10
11. Manual version .....	11



## 1. summary

PRO RANGE-KE 200 is an intelligent non-contact induction switch, integrating infrared reception and control, equipped with anti-sunlight interference function, the sensing distance under sunlight can reach 150cm, and compatible with indoor and outdoor use; the sensor uses infrared light, when the object, in the front of the sensor, the sensor immediately enters the sensor state, so as to control the output signal; if the person or object leave the sensing range, and remove the output signal to achieve the purpose of intelligent control (reverse output can also be customized).

## 2. application environment

It can be used for: security alarm, induction light, intelligent trash can, mirror light box, advertising machine, shoe cleaning machine, induction water dispenser, vending machine, faucet, shower head and other functions.

Instructions for Use: Based on the working principle of infrared diffuse reflection, the induced distance determined by the sensor is offset by the intensity of the ambient light and the color of the detected object ( $\pm 30\text{cm}$ ).

## 3. Product selection (this product has various specifications as follows)

order number	model	output signal
1	PRO RANGE-KE200-M/5~24V	Relay normally open 5V-24V output
2	PRO RANGE-KE200-MC/5~24V	Relay normally closed 5V-24V output
3	PRO RANGE-KE200N	NPN collector open circuit output (normally open) DC 5V-24V
4	PRO RANGE-KE200NC	NPN collector open circuit output (normally closed) DC 5V-24V
5	PRO RANGE-KE200V	High and low level signal output (positive output) 5V-24V

## 4. technical parameter

project name	parameter		
working voltage	DC 5V~24V		
sensing distance	From 5 cm to 200 cm indoors	From 5 to 150 cm outdoors	Direct sunlight is 5-100cm
Induction accuracy	Indoor room $\pm 5\text{cm}$	Outdoor $\pm 10\text{cm}$	Direct sunlight is $\pm 30\text{cm}$
response time	$\leq 500\text{ms}$		
Induction Angle	The 30-40° conical angle		
Induction mode	Active		

quiescent current	<3.5 mA
load current	<1A
operating ambient temperature	-20 ~ 85°C
Storage temperature	-20 ~ 85°C
wire length	30cm (± 10MM) (batch customizable)
material quality	The PC-V0 fireproof material
Waterproof performance	IP67
Safety standards certification	CE
Environmental certification	ROHS-2.0

## 5. The wiring principle

### a) PRO RANGE-KE200-M-NO wiring schematic diagram

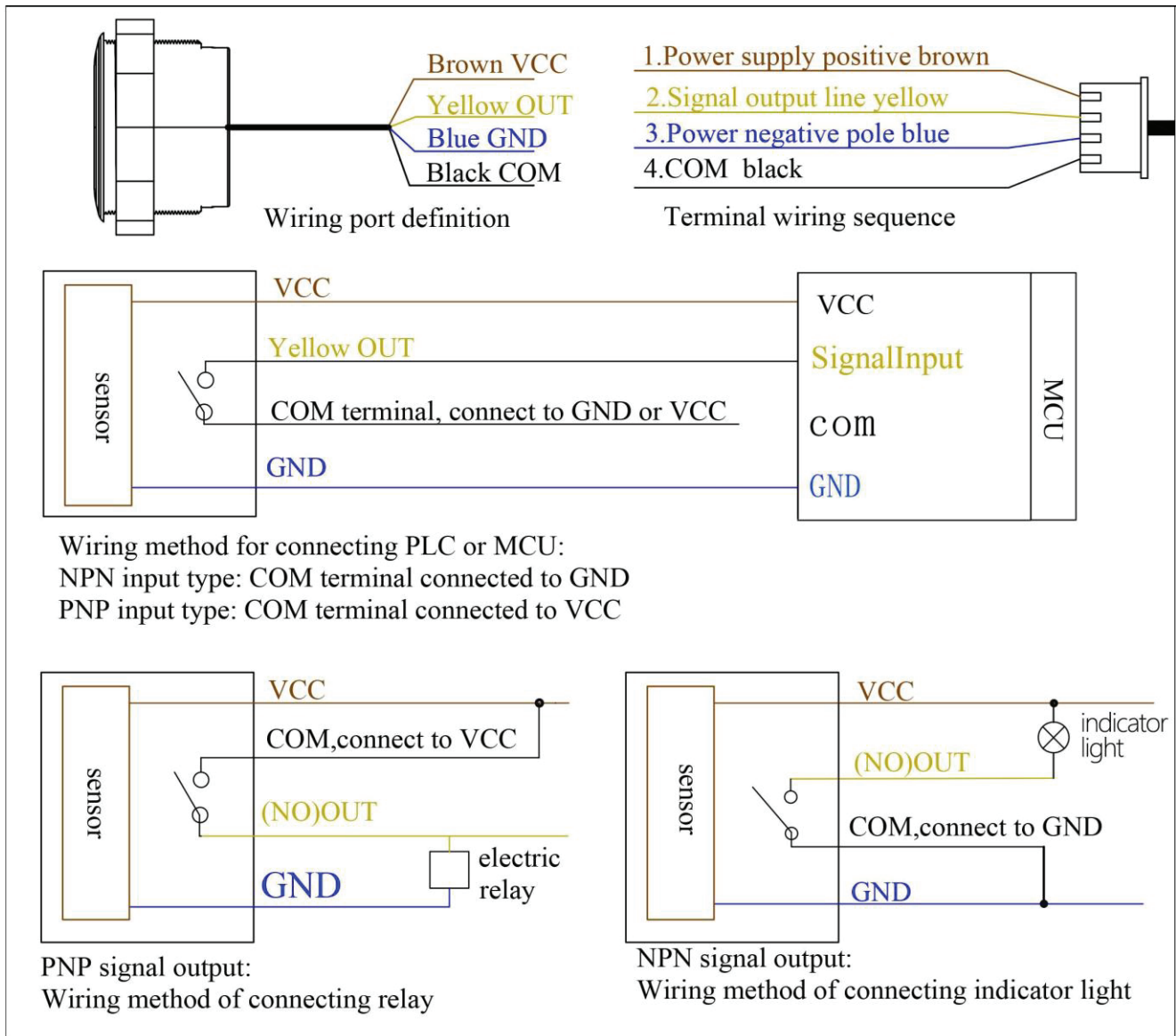

Operating principle of relay point NO output:

1. When the black line is connected to the VCC:

When sensing the object, the relay is closed, the relay NO point conduction, and the output VCC voltage;

When the relay is not disconnected to the object, the relay NO point is disconnected;

2. When the black wire connects to the GND:

When sensing the object, the relay is closed, the relay NO point conduction, and the output GND voltage;

When the relay is not disconnected to the object, the relay NO point is disconnected;

## b) PRO RANGE-KE200-M-NC wiring schematic diagram

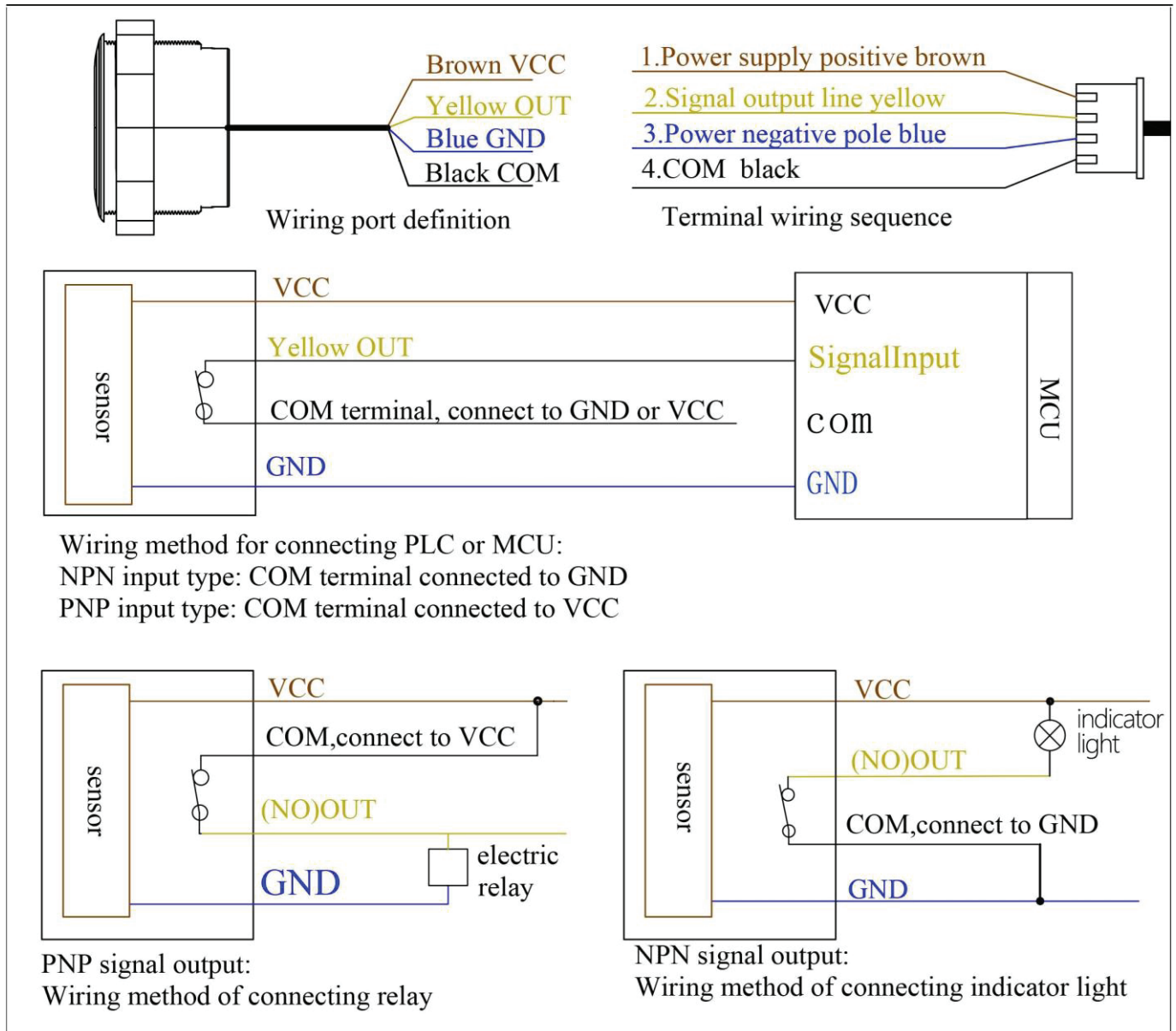

Operating principle of relay NC point output:

1. When the black line is connected to the VCC:

When the object is induced, the relay is closed, and the relay NC point is disconnected;

When the object is not induced, the relay is disconnected, the relay NC point is on, and the output VCC voltage;

2. When the black wire connects to the GND:

When the relay is closed, the relay NC point O is disconnected;

When the object is not induced, the relay is disconnected, the relay NC point is on, and the output GND voltage;

## c) PRO RANGE-KE200-NPN wiring schematic diagram

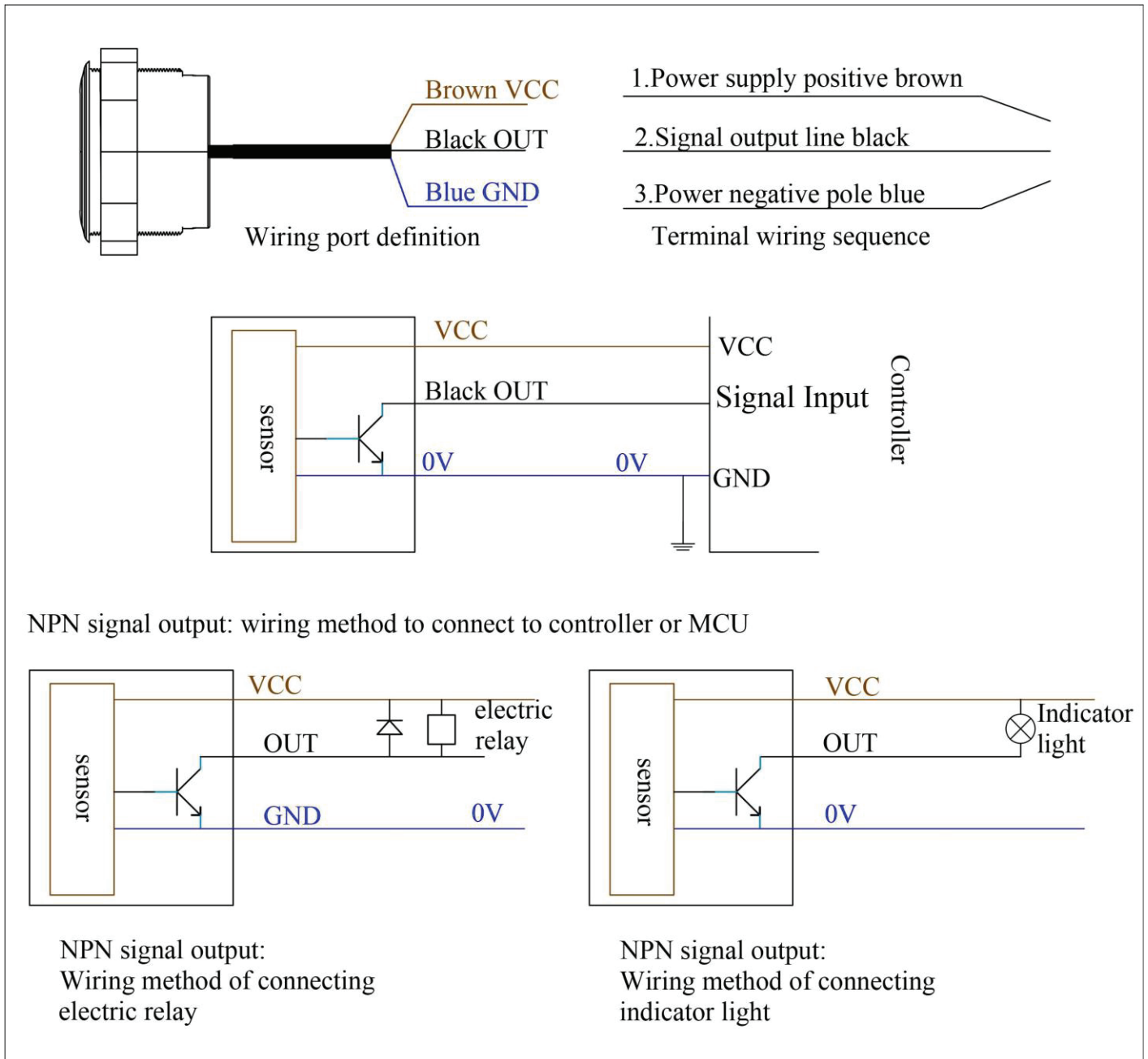

## d) PRO RANGE-KE200-V Schematic diagram of high and low level wiring

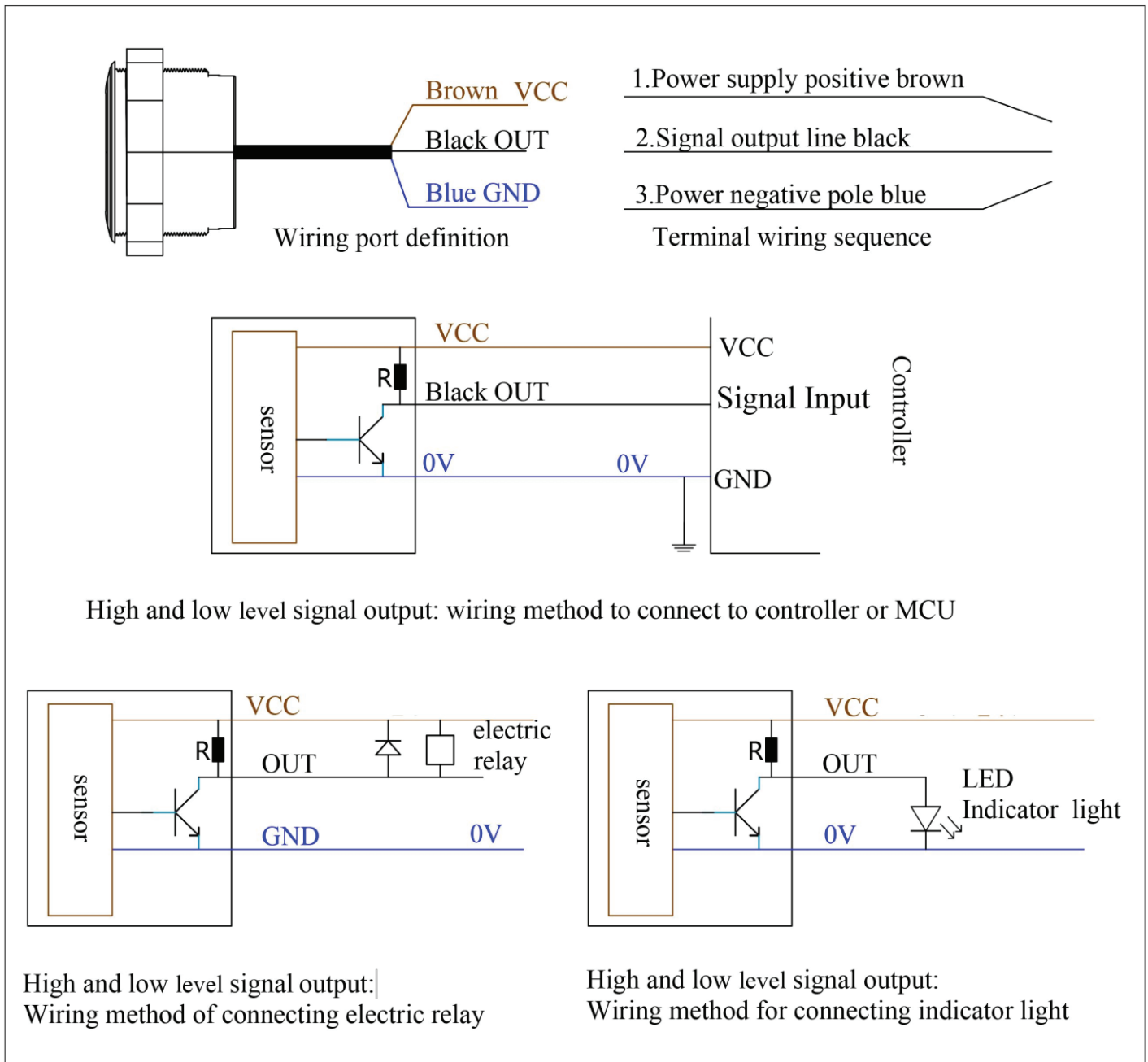

## 6. Installation method

Open holes in the panel where the sensor needs to be installed with an aperture of 28mm. Install the sensor from the front of the panel and tighten the nut behind the sensor.

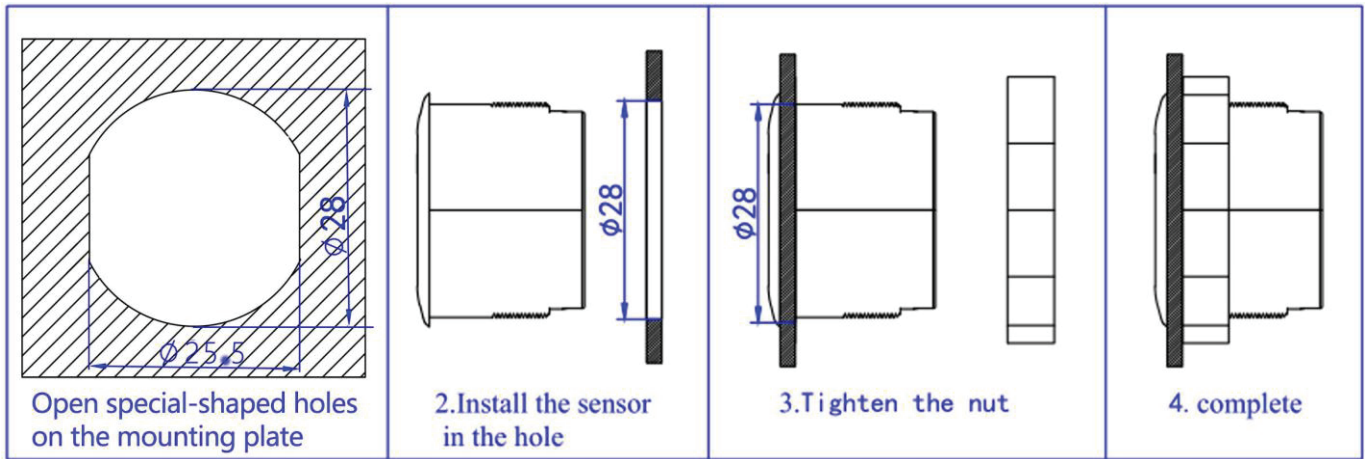

## 7. Induction distance adjustment

The sensor is in the normal operating state, placing approximately 80x60cm of kraft cardboard less than or equal to 80cm directly in front of the sensor. The induction distance adjustment step is shown in the figure below

Enter the pitch mode: open the back cover, long press the button, when the red LED indicator light flashes, enter the automatic pitch mode.

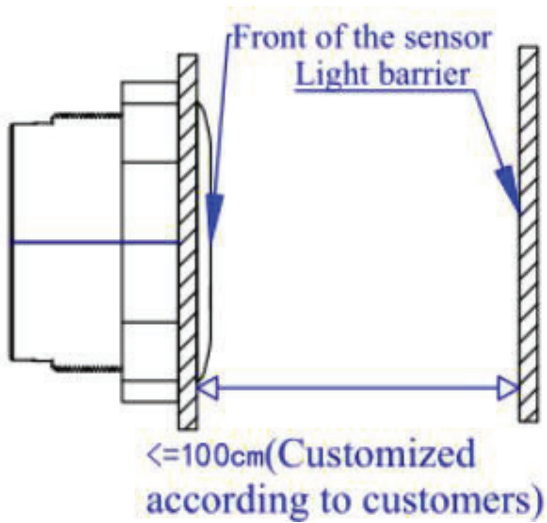

### Induction distance adjustment process

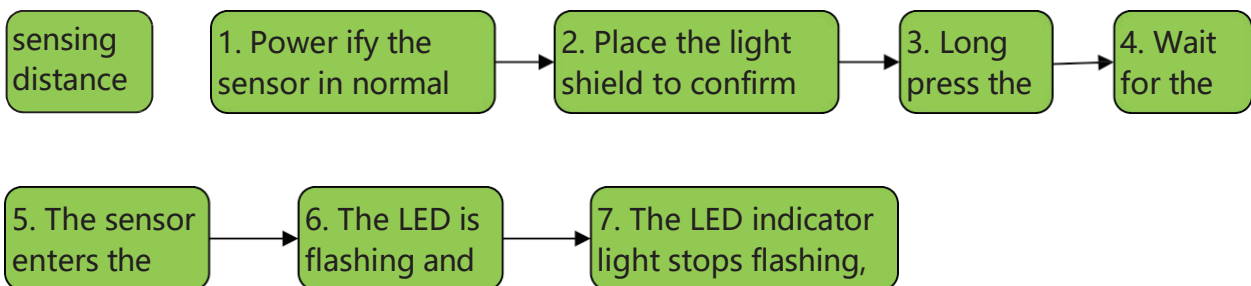



## 8. dimensions and physical drawings



The tooth pitch is M27.5\*0.8mm.

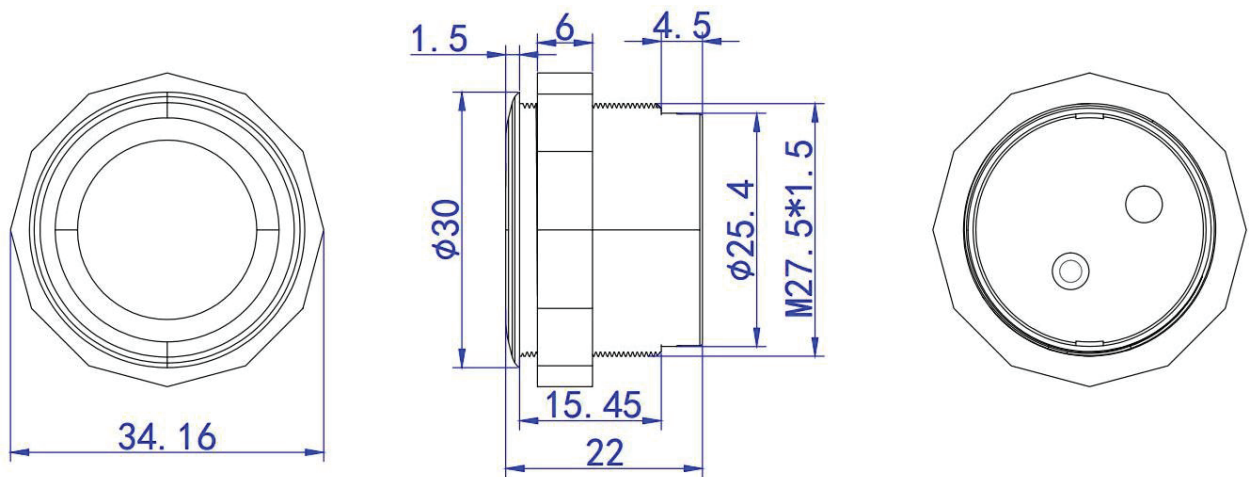

## 9. induction range and angular displacement

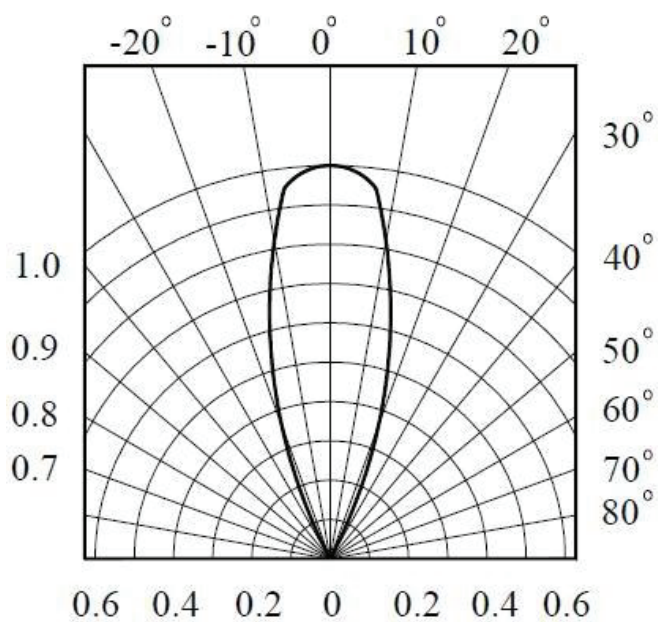

## 10. Product warranty terms and description

### (I) Warranty service

1. Warranty maintenance: from the date of purchase, the product host is free for one year. The Company has the right to decide to repair or replace the faulty parts. If the replacement parts, the replacement parts may be new equipment or repair goods with the same category, function and quality. The replaced faulty parts shall be owned by the Company; the resale and maintenance of the products shall not affect the warranty period, and the products repaired or replaced shall continue to enjoy the original remaining warranty services; if less than three months after the end of the warranty period, the repaired or replaced products shall be repaired by customers.

2. Loss upon arrival (DOA) replacement: from the date of purchase, you can enjoy within 7 days of free replacement service of the equipment. The products with the following problems is defined as DOA equipment: inconsistent; part or all of the components of the product are not used normally (surface scratches or other defects that do not affect the function of the equipment are not included); other hardware faults identified by remote or local inspection by the engineers of the Company.

(2) Limitations of the application of the warranty The Company does not assume any warranty liability for:

1. The product exceeds the warranty period; the surface of the product is badly damaged, installation / use under abnormal environment, unauthorized disassembly, repair / modification, external power supply injury and other abnormal damage;

2. Damage caused by the wrong installation and use of the product when the user fails to follow the requirements of the manual;

3. Damage caused by natural disasters and man-made negligence (fire, lightning strike, water flooding, impact, etc.).

(III) The accessories and consumables are not covered by the warranty.

### (IV) Non-free warranty service

Within two years of the purchase of the product, for the products (including parts) not under warranty, you can choose the paid maintenance service (free of labor cost), and we will charge the transportation cost of the parts and accessories of the repair product according to the actual situation.

### (V) Access to warranty services

Recommend you to contact the dealer to buy this product for warranty service, warranty please show valid warranty card (dealer stamp effect) or purchase invoice / receipt: if not show, the product free warranty to 12 months from the date of delivery, the latest DOA application period, to 7 days from the date of delivery.

### (VI) Statement

1. The copyright of this manual belongs to Shenzhen Pro Range Technology Co., LTD.

(Pro Range) and its licensors, and Shenzhen Pro Range Technology Co., LTD. (Pro Range) reserves all rights.

2. Without the written permission of the Company, no unit or individual shall copy or copy part or all of the contents of this manual, and shall not disseminate them in any form.

3. Customers agree that the design and production purpose of the company's products do not involve other systems or products related to life guarantee or used in other dangerous activities or environment. Failed products can cause personal casualties, property or environmental damage (collectively referred to as high-risk activities). The Company shall not provide warranty for the use of our products in high-risk activities and shall not be liable to customers or a third party.

4. The contents of this manual may be changed due to the product version upgrade or other reasons. Pro Range reserves the right to modify the contents of this manual without any notice or prompt. This manual is only used as a guide for use, and Pro Range tries its best to provide accurate information in this manual. However, Pro Range does not ensure that the contents of the manual are completely free of errors, and all statements, information and suggestions in this manual do not constitute any express or implied guarantee.

5. Not all models are available in all countries

Please keep this instruction properly. Before using the product, please read the manual carefully. When using the product, please be sure to follow the manual. The company will not be responsible for any injuries and accidents caused by it.

(7) Environmental protection

The product meets the design requirements for environmental protection, and the storage, use and disposal of the product shall be conducted in accordance with the relevant national laws and regulations.

## 11. Manual version

version number	date of issue
V10	2023-06-14