

## Non-contact liquid level sensor instruction manual

(Intelligent externally attached pipeline detection liquid level special series products)

### Model PRO RANGE-Y26A-V

#### Table of Contents

1st. Overview.....	2
2nd.Product Features.....	2
3rd.Product Applications.....	2
4th.Product parameter.....	3
5th.product selection.....	3
6th.Installation method.....	3
7th. Sensitivity adjustment.....	4
8th. Product size and physical map.....	5
9th.Y26A wiring diagram of various models.....	6
10th.Other matters needing attention.....	7
11th.Troubleshooting.....	8
12th.Product warranty terms and instructions.....	8
13th. Manual version.....	10



## 1st. Overview

The intelligent non-contact liquid level sensor (hereinafter referred to as the liquid level sensor) adopts advanced signal processing technology and high-speed signal processing chip, which breaks through the influence of container wall thickness and realizes a true non-contact type of liquid level height in a closed container Detection. The liquid level sensor (probe) is installed on the upper and lower sides of the outer wall of the container to be measured (the high and low levels of the liquid level). The non-metallic container does not need to be opened, and the installation is simple and does not affect production. It can detect the liquid level of various liquid toxic substances, strong acids, strong alkalis and various liquids in high-pressure airtight containers. The liquid level sensor has no special requirements for the material of the liquid medium and the container, and can be widely used. PRO RANGE-Y26A-XXX series products are specially developed for non-metallic pipeline liquid level detection. This series of liquid level sensors are divided into three signal output control methods: high and low level output interfaces, NPN output interfaces, and PNP output interfaces; The signal output mode corresponds to the following three models:

Serial number	type number	signal interface
1	XKC-Y26A-V	High and low level output interface
2	XKC-Y26A-NPN	NPN output interface
3	XKC-Y26A-PNP	PNP output interface

## 2nd. Product Features

1. PRO RANGE-Y26A-XXX non-contact liquid level sensor is suitable for all kinds of non-metal containers. The product detects the liquid through the detection signal through the non-metal container and the outer wall of the pipeline, without direct contact with the liquid. It is corroded by strong acids and alkalis and other corrosive liquids, and is not affected by scale or other debris, and it can be completed to detect whether there is liquid inside the container or pipeline.
2. Product design intelligent liquid level reference adjustment and liquid level memory function, liquid level status display mode, can realize multi-point series connection control mode. It can support high and low level output, NPN, PNP signal output control (please refer to the manufacturer's instructions when selecting the model).
3. The detection liquid level is accurate and stable, and cold, hot and boiling liquids can be detected.
4. Pure electronic circuit structure, non-mechanical working mode, stable performance and long-lasting service life.
5. High stability, high sensitivity, strong anti-interference ability, free from external electromagnetic interference, special treatment for power frequency interference and common mode interference, to be compatible with all 5~24V power adapters on the market.
6. Wide range of application, strong sensing ability, can penetrate and detect the liquid level in various non-metallic containers and pipes, such as plastic, glass, ceramics and other containers. The thickness of the sensing pipe wall can reach 20mm; it can be applied to various curved surfaces., Arc, cylindrical and other irregular containers or pipeline liquid level detection.
7. Wide voltage range (5~24V), suitable for connecting various circuits and product applications

## 3rd. Product Applications

The intelligent non-contact liquid level sensor uses the inductive capacitance of water to detect the presence of liquid. When there is no liquid close to the sensor, the sensor has a certain static capacitance to the ground due to the presence of

# Pro Range

distributed capacitance on the sensor. When the liquid level is slow When the sensor is slowly raised, the parasitic capacitance of the liquid will be coupled to the static capacitance of the sensor, making the capacitance value of the sensor larger. The changed capacitance signal is then input to the control IC for signal conversion, and the changed capacitance is converted into a circuit signal When the amount of change exceeds a certain threshold, it is judged that the liquid level has reached the sensing point.

## 4th.Product parameter

Project name	Parameters
Product model	PRO RANGE-Y26A-V
Supply voltage (Vin)	(DC 5-24V)
Output mode	High and low level
electric current	≤5mA
The output voltage (high pulse)	Vin
The output voltage (low level)	0V
The output current	≤100mA
Response time	500mS
Working temperature	-20~105°C
Applicable pipe diameter range	Outer diameter 5mm~10mm
Liquid level accuracy	±1.5mm
humidity	5%~100%
Material	PC V0 Fireproof material
Waterproof performance	IP67
Safety standard certification	CE
Environmental protection certification	ROHS-2.0

## 5th.product selection

High and low level output interface — Model: PRO RANGE-Y26A-V (DC 5-24V)

## 6th.Installation method

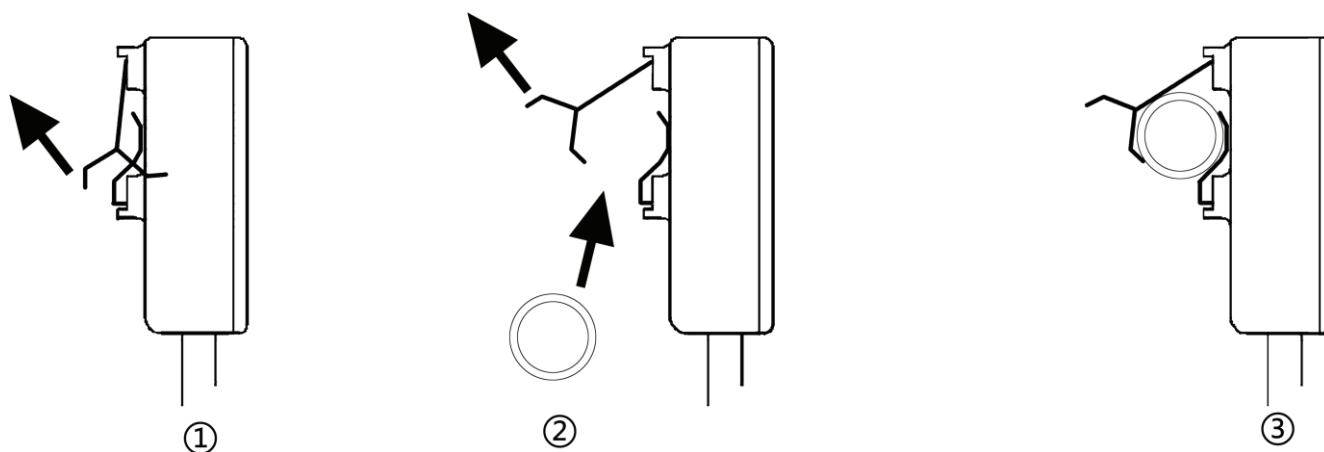

①. Pull open the shrapnel

# Pro Range

- ②. Pull the shrapnel and put the water pipe between the two shrapnels
- ③. Just let go of the shrapnel

After installation, the effect is as follows.

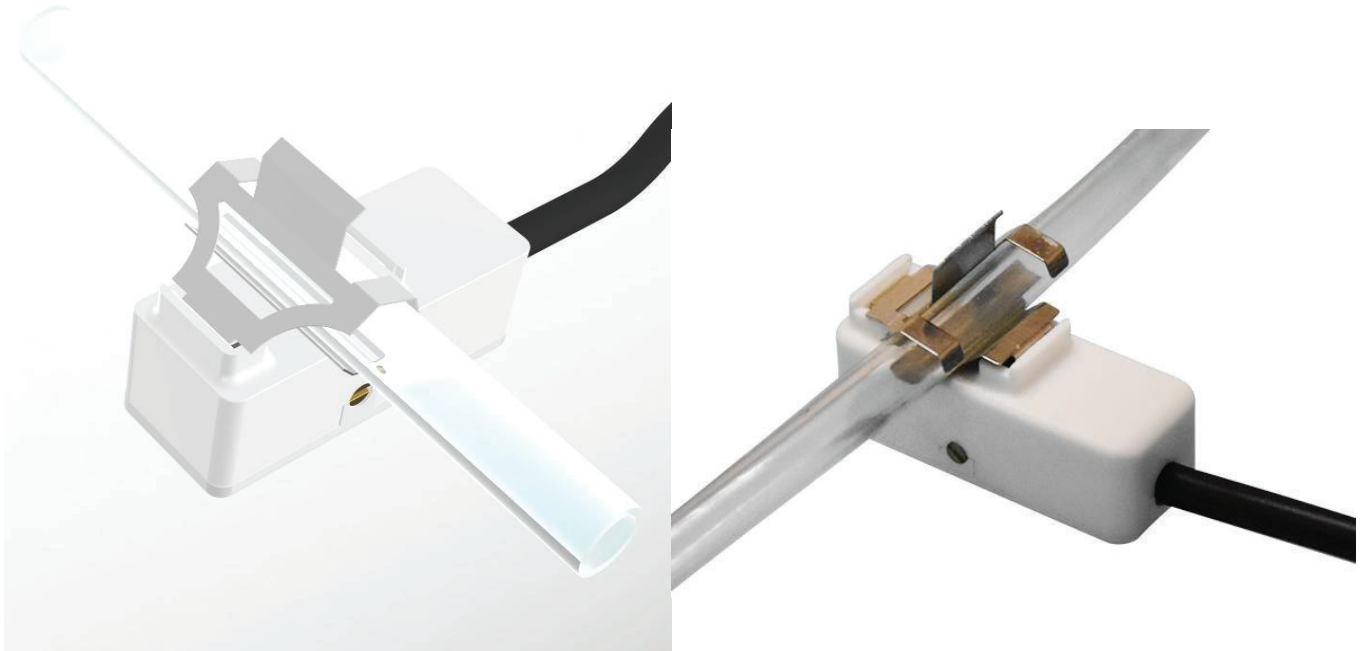

note:

1. This product is suitable for pipes with an outer diameter of 5mm ~ 10mm, and the maximum shall not exceed 11mm
2. The maximum opening angle of the spring leaf shall not exceed 60°

## 7th. Sensitivity adjustment:

If the non-contact liquid level sensor cannot detect or the detected liquid level deviates from the Y26A sensor, The sensitivity knob can be adjusted with a small screwdriver. Setting method:

1. Turn counterclockwise to increase sensitivity.
2. Turn clockwise to lower the sensitivity.

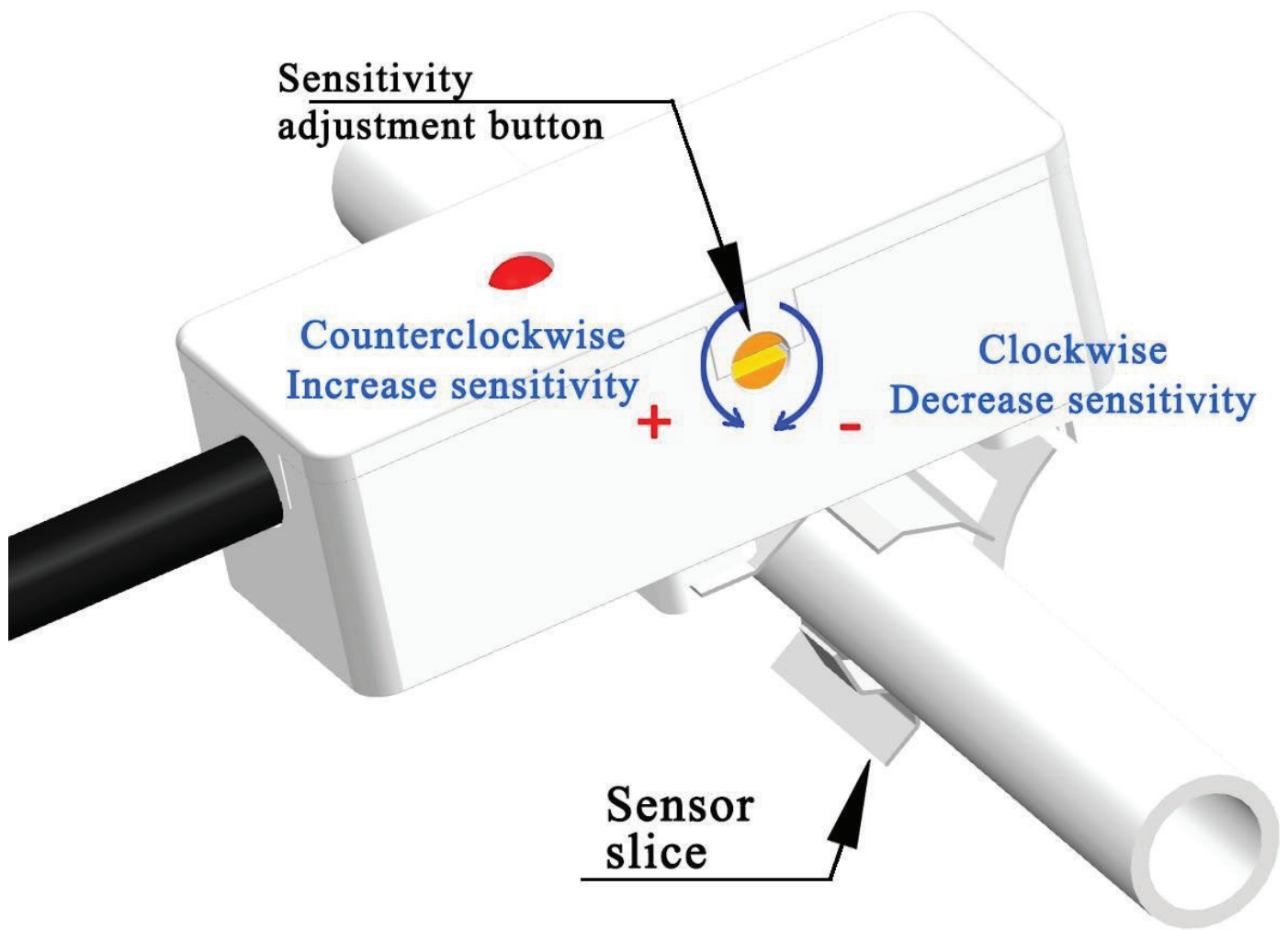

## 8th. Product size and physical map



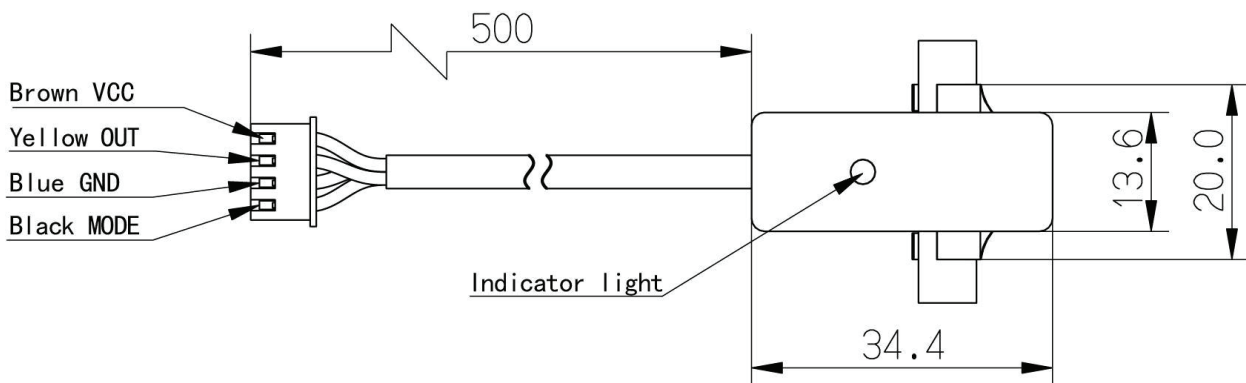
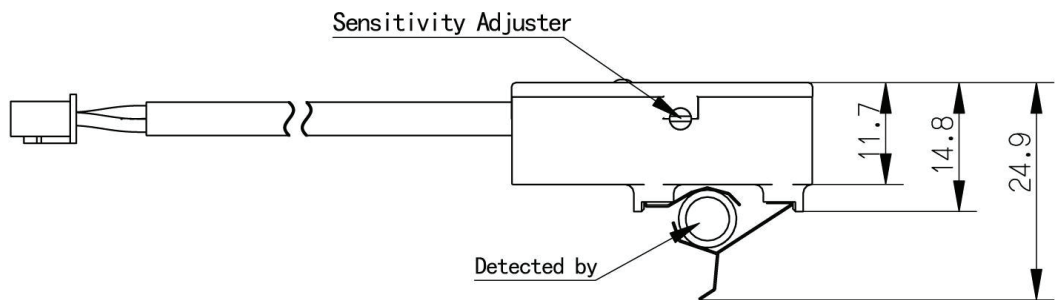
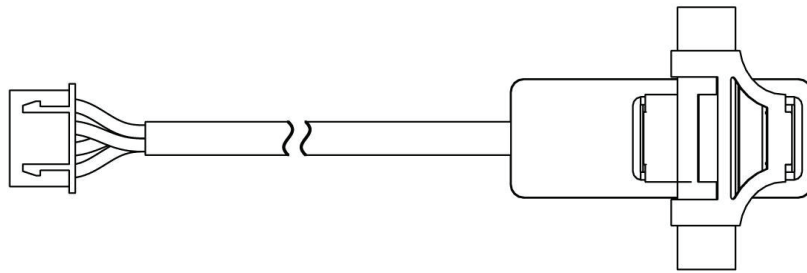
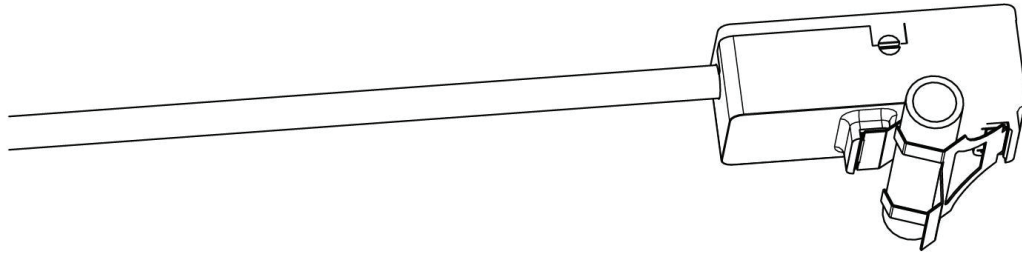

## 9th.Y26A wiring diagram of various models

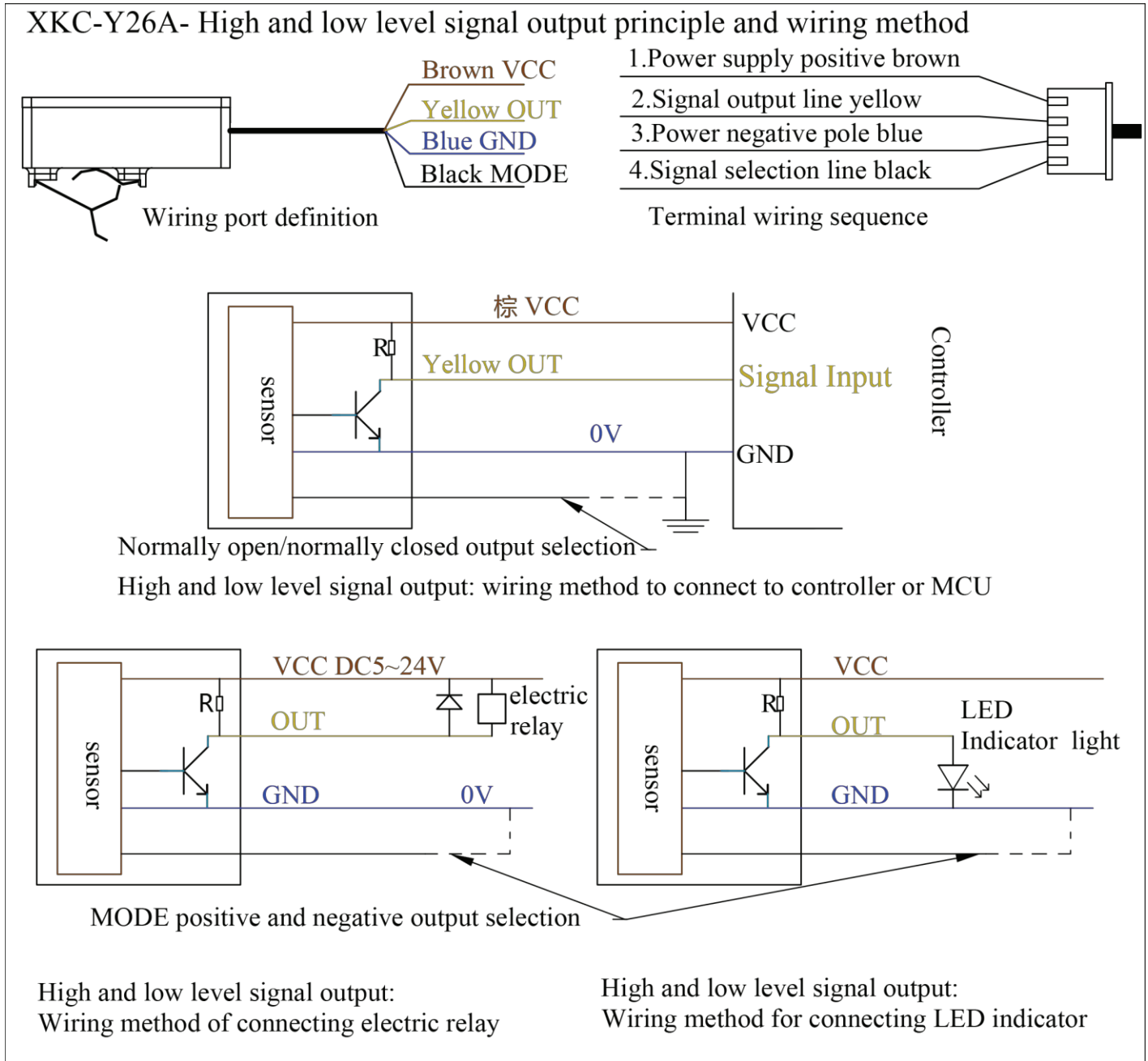

High and low level output drive small electric relay (coil current  $\leq 100\text{mA}$ ) Product Applications:

1. When the black line is suspended, it is positive output:

When liquid is sensed, the transistor cuts off and outputs a high level, and the relay does not pull in when it is powered off;  
When no liquid is sensed, the transistor turns on and outputs a low level, and the relay is energized and closed.

2. When the black wire is grounded (connected to the negative pole of the power supply 0V), it is a reverse output:

When liquid is sensed, the transistor turns on and outputs a low level, and the relay is energized and closed;

When no liquid is sensed, the transistor cuts off and outputs a high level, and the relay does not pull in when it is powered off.

### 10th. Other matters needing attention

(1) The viscosity of the measured liquid medium

When the dynamic viscosity is less than  $10\text{mPaS}$ , it is measured normally.  $10\text{mPaS} < \text{dynamic viscosity} < 30\text{mPaS}$  may

affect the detection. When the dynamic viscosity is greater than 30mPaS, it cannot be measured because a large amount of liquid adheres to the container wall.

(2) Note: As the temperature increases, the viscosity decreases, and most high-viscosity liquids are more affected by temperature. Therefore, pay attention to the influence of liquid temperature when measuring viscous liquids.

(3) Pay attention to keeping the level gauge clean, try to prevent corrosion and avoid violent collisions and blows from other objects.

(4) During outdoor installation, avoid direct sunlight and rainwater directly flowing to the main body of the level gauge, and keep away from high heat sources and pay attention to ventilation. If the ambient temperature exceeds the rated temperature, corresponding cooling protection measures should be taken.

(5) When the ambient temperature is lower than the normal operating temperature range of the level gauge, an instrument protection box or other protective rain cap devices can be used for antifreeze protection, and pay attention to keeping the level gauge dry. The sensor should be regularly maintained and inspected. (The detection time interval is determined by the use unit according to the specific situation).

## 11th.Troubleshooting:

Fault status	Analyze the reasons	Problem solving measures
After the liquid level sensor is energized, there is no response (the indicator light does not light when the water level reaches the sensing point, and the sensitivity adjustment has no response)	①The power cord is not connected	Check and connect the power
	② The positive and negative ends of the power cord are reversed	Correct wiring
	③The power module is damaged	Replace the circuit board where the power module is located
	④Sensitivity is too low	Adjust the sensitivity to the appropriate gear
The indicator light keeps on	①Sensitivity grade is too high	Adjust the sensitivity to the appropriate grade
	②The initialization parameters are abnormally modified	Return to the factory to reinitialize
	③The sensor has debris or other metal parts close to it	Clean up debris and keep a certain distance from metal parts

## 12th.Product warranty terms and instructions

### (A). Warranty service

1. Warranty period maintenance: from the date of purchase, the product host has a one-year free warranty. The company has the right to decide to repair or replace the faulty part. If it is replaced, the replacement part may be a new device or a repair product of the same category, function, and quality. The replaced faulty part belongs to the company; the product Resale and repair do not affect the warranty period. Products that have been repaired or replaced continue to enjoy the original remaining warranty period service. If the warranty period is less than three months after the repair, the repaired or replaced part shall be shipped from the date of delivery Warranty for three months; all products of the company are guaranteed for repair.



2. Loss upon arrival (DOA) replacement: From the day of purchase, you can enjoy a free replacement service within 7 days. Products with the following problems are defined as DOA equipment: the packing and packing list do not match after the first unpacking of the product; some or all of the components cannot be used normally after the first unpacking of the product (surface scratches or other things that do not affect the function of the device) Defects are not included); other hardware failures identified by our company's engineers remotely or locally.

## (B). Applicable limitations of warranty

For the following situations, the company does not assume warranty responsibility:

1. The product is out of warranty; the surface of the product is fragile and damaged; the appearance of the product is seriously damaged, installation/use in abnormal environment, unauthorized disassembly and repair/modification, external power supply damage and other abnormal damage;
2. Damage caused by incorrect installation and use of the product by the user not following the requirements of the manual;
3. Damage caused by natural disasters and human negligence (fire, lightning, flooding, impact, etc.).

(C) . Accessories and consumables are not covered by the warranty.

## (D) . Non-free warranty service

Within two years of product purchase, for non-warranty product (including components) failures and damages, you can choose paid maintenance services (free labor costs), and we will charge the transportation cost of repairing parts and accessories according to the actual situation.

## (E). Ways to obtain warranty service

It is recommended that you contact the dealer who purchased this product to obtain the warranty service. For the warranty, please present a valid warranty card (the dealer's stamp is required to take effect) or the purchase invoice/receipt: if you can't show it, the product's free warranty period 12 months from the product shipment date, and the latest DOA application deadline is 7 days from the product shipment date.

## (F). Statement

1. The copyright of this manual belongs to Shenzhen Pro Range Technology Co., Ltd. (Pro Range) and its authorized licensors. Shenzhen Pro Range Technology Co., Ltd. (Pro Range) reserves all rights.
2. Without the written permission of the company, no unit or individual may excerpt or copy part or all of the contents of this manual, and shall not spread it in any form.
3. The customer recognizes that the purpose of the design and production of the company's products does not involve use in products related to life support or other systems or products used in other dangerous activities or environments. Personal injury or death, property or environmental damage due to product failure (collectively referred to as high-risk activities). The company's products are artificially used in high-risk activities, and the company does not guarantee it and is not liable to customers or third parties.
4. Due to product version upgrades or other reasons, the contents of this manual may change. Pro Range reserves the right to modify the contents of this manual without any notice or prompt. This manual is only used as a guide. Pro Range makes every effort to provide accurate information in this manual. However, Pro Range does not guarantee that the contents of the manual are completely free of errors. All statements, information and suggestions in this manual do not constitute any express or Implied guarantee.
5. Not all models are available in all countries/regions

Please keep this manual properly. Before using the product, please read this manual carefully. When using the product, please be sure to operate in accordance with this manual. The company is not responsible for injuries and accidents caused by operations that do not follow this manual.

(G). Environmental protection This product meets the design requirements for environmental protection. The storage, use and disposal should comply with relevant national laws and regulations. Seek to proceed.

## 13th. Manual version

Version	Release date
V2.0	September 28, 2022