

Ultra-High Performance Time-of-Flight (ToF) Sensor



Features

- Fast, accurate distance ranging
 - Measures absolute range up to 40m (white target) with accuracy indication
 - Adaptive output data rate up to 54Hz
 - Measuring result is not sensitive to the target color and reflectivity
 - Embedded electrical & optical cross-talk compensation
 - -10°C~+55°C temperature compensation
 - Ambient light compensation enables accurate measurement in high infrared ambient light levels
- Fully integrated miniature module
 - 850nm infrared VCSEL emitter
 - Emitter driver
 - Integrated optimally-designed emitting & receiving optical lens
 - Ranging sensor with advanced embedded micro controller
 - Advanced embedded data processing & filtering algorithm
 - 115200bps 3.3V UART interface
 - 35(W) x 24(H) x 21.5(D) mm, 8g
 - Compliant with latest CE, FCC, RoHS standards

Applications

- Drones (collision avoidance, soft-landing)
- Robotics & AGV (obstacle detection)
- Industrial location and proximity sensing
- Security and surveillance
- 1D gesture recognition

Description

HPS-167-L is an upgraded ultra-high-performance Time-of-Flight (ToF) infrared ranging sensor with newly-designed emitting & receiving optical lens, suitable for precise, long-distance measurements. It provides accurate distance measurement whatever the target color and reflectivity unlike conventional technologies. HPS-167-L can measure absolute distances up to 40m on a white target, setting a new benchmark in ranging performance levels, opening the door to various new applications.

HPS-167-L integrates a high-power 850nm infrared VCSEL emitter and a high-sensitivity photodiode (PD) coupled with internal physical infrared filters, enables longer ranging distance and higher immunity to ambient light.

Advanced embedded data processing & filtering algorithm realizes extremely stable and real-time measurement outputs.

CE FCC RoHS



**AVOID EYE OR SKIN
EXPOSURE TO DIRECT OR
SCATTERED RADIATION**

Overview

1.1 Technical specification

Table 1. Technical specification

Parameter	Values	Unit
Size	35(L) x 24(W) x 21.5(H) *	mm
Weight	7 * ¹	g
Power supply	4 ~ 6	V
Maximum power consumption	1.3	W
Quiescent power consumption	0.1	W
Storage temperature	-40 ~ 85	°C
Operating temperature	-10 ~ 55 * ²	°C
Infrared VCSEL emitter	850	nm
Emitting angle	±1.6	°
Maximum measuring distance	40 * ³	m
Minimum measuring distance	0.08	m
Output data rate	6 ~ 54	Hz
Output data	Distance, accuracy, signal strength, ambient IR level, temperature	-
Connector	0.5mm-pitch, 8-pin, FPC connector, top and bottom double contacts	-
Interface	TTL UART, 115200bps, 8 data bits, no parity, 1 stop bit	-

Note: *1 Without lens cover.

*2 In continuous ranging mode, HPS-167-L needs a few seconds warm-up time to stabilize the output.

Attention needs to be paid to the heat dissipation of PCB board to avoid the increasing of thermal circuit noise.

*3 Tested on 90% reflectance white target.

1.2 Mechanical drawing & device pinout

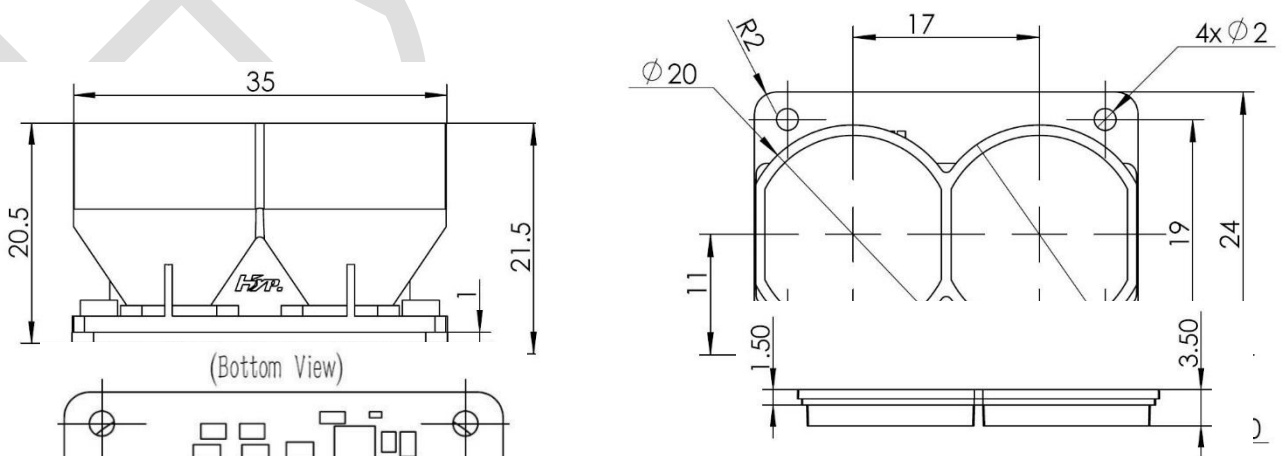
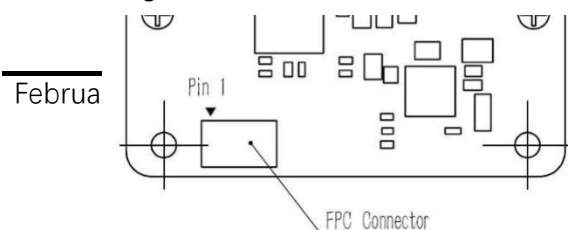

Figure 1. Front view of HPS-167-L



Rev 1.3

15

Figure 3. Bottom view of HPS-167-L

Figure 4. Front and bottom view of lens cover

Table 2. HPS-167-L pin description

Pin number	Signal name	Signal type	Description
1	VDD	Power	Supply, to be connected to main supply (typical +5V)
2	VDD	Power	Supply, to be connected to main supply (typical +5V)
3	GND	GND	Ground
4	GND	GND	Ground
5	INT	Digital output	Interrupt signal output (pulse width: 100us)
6	RST	Digital input	Reset signal input, active low
7	RXD	Digital input	UART TTL input
8	TXD	Digital output	UART TTL output

All pins are compliant with IEC61000-4-2 ESD Immunity Test values presented in Table 3

Table 3. ESD performances

Parameter	Conditions
Air Discharge	+/- 8kV
Direct Contact	+/- 4kV
Indirect Contact HCP	+/- 4kV
Indirect Contact VCP	+/- 4kV

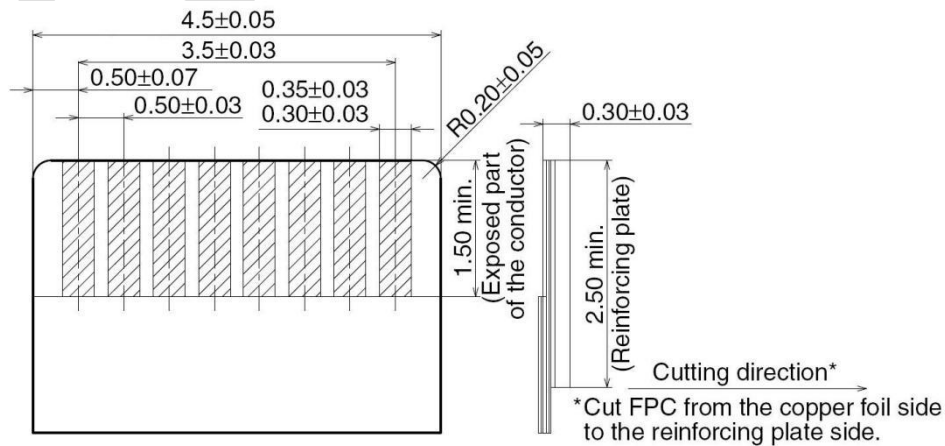

Figure 5. Recommend FPC/FFC dimensions

1.3 Absolute maximum ratings

Table 4. HPS-167-L pin absolute maximum ratings

Parameter	Min.	Typ.	Max.	Unit
VDD	-0.3	-	6.5	V
RXD, RST	-0.3	-	5.6	V

Note: Stresses above those listed in Table 4. may cause permanent damage to the device. This is a stress rating only and functional operation of the device at these or any other conditions above those indicated in the specification is not implied. Exposure to absolute maximum rating conditions for extended periods may affect device reliability.

1.4 Recommended operating conditions

Table 5. HPS-167-L pin recommended operating conditions

Parameter	Min.	Typ.	Max.	Unit
VDD	4	5	6	V
RXD, RST	2.8	3.3	3.6	V

1.5 Application schematic

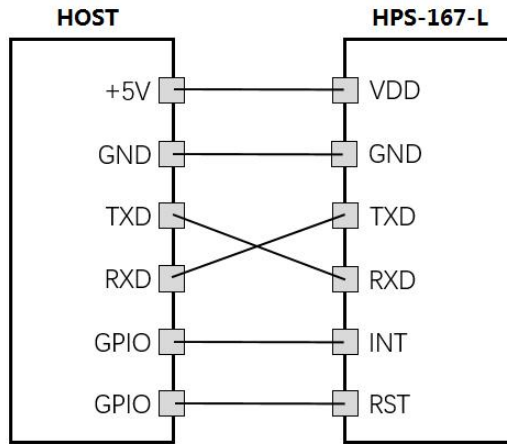

Figure. 6 Application schematic of the HPS-167-L

Control interface

2.1 TTL UART serial interface

HPS-167-L has a TTL UART interface and can communicate with any host that has a TTL UART interface. The logical level corresponds 3.3V powered logics.

Table 6. UART properties

Baud rate	115200bps
Start bit	1bit
Data bit	8bits
Parity bit	0bit
Stop bit	1bit

2.2 Communication protocols

After the sensor is powered up, system automatically performs the initialization procedures and the serial interface will output “Hypersen” if the initialization succeeded. A start byte “0x0A” is used to indicate the start of each command and returned data frame. Each HPS-167-L has its universally unique identifier (UUID), which can be read out by sending a command from the host.

Command #1: Acquire the sensor information

Table 7. Acquire the sensor information command

Start byte	Command field	Data field						CRC MSB	CRC LSB
		Byte 2	Byte 3	Byte 4	Byte 5	Byte 6	Byte 7		
Byte 0	Byte 1	Byte 2	Byte 3	Byte 4	Byte 5	Byte 6	Byte 7	Byte 8	Byte 9
0x0A	0x2E	0x00	0x00	0x00	0x00	0x00	0x00	0xFC	0x3C

Returned data:

Table 8. Returned data of acquire the sensor information command

Byte No.	Name	Value	Description
0	Start byte	0x0A	Start byte of the returned data frame
1	Data length	0x18	Length of the data field, it does not include byte No.0 and byte No.1
2	ACK byte	0xB0	Acknowledgment byte
3~18	UUID	Universally unique identifier of device
19	Year	Production date
20	Month	
21	Day	
22	Major version	Device version
23	Minor version	
24	CRC MSB	CRC values of current data frame (Byte No.2 to No.23)
25	CRC LSB	

The following is an example of the returned sensor information data:

0x0A 0x18 0xB0 0x52 0x13 0x29 0x8C 0xC7 0xE0 0xE5 0x11 0x8D 0x2B 0xB9 0x57 0x2C 0xF3 0xAD 0x25 0x10 0x0A 0x08 0x01 0x09 0x22 0xE9

Decoding:

0x0A: Start byte

0x18: Data length (24 byte data)

0xB0: Acknowledge

0x52 0x13 0x29 0x8C 0xC7 0xE0 0xE5 0x11 0x8D 0x2B 0xB9 0x57 0x2C 0xF3 0xAD 0x25: UUID

0x10 0x0A 0x08: 16/10/08

0x01 0x09: Ver. 1.9

0x22 0xE9: CRC16-CCITT MSB and LSB byte

Command #2: Continuous ranging

Table 9. Continuous ranging command

Start byte	Command field	Data field						CRC MSB	CRC LSB
		Byte 2	Byte 3	Byte 4	Byte 5	Byte 6	Byte 7		
Byte 0	Byte 1	Byte 2	Byte 3	Byte 4	Byte 5	Byte 6	Byte 7	Byte 8	Byte 9
0x0A	0x24	0x00	0x00	0x00	0x00	0x00	0x00	0x0F	0x72

Command #3: Single ranging

Table 10. Single ranging command

Start byte	Command field	Data field						CRC MSB	CRC LSB
		Byte 2	Byte 3	Byte 4	Byte 5	Byte 6	Byte 7		
Byte 0	Byte 1	Byte 2	Byte 3	Byte 4	Byte 5	Byte 6	Byte 7	Byte 8	Byte 9
0x0A	0x22	0x00	0x00	0x00	0x00	0x00	0x00	0xAE	0x57

Returned data:

Table 11. Returned data of ranging results

Byte No.	Name	Value	Description
0	Start byte	0x0A	Start byte of the returned data frame
1	Data length	0x0D	Length of the data field, it does not include byte No.0 and byte No.1
2~4	Reserved	Reserved
5	Distance MSB	Measured distance, unit: mm
6	Distance LSB	
7	Magnitude MSB	Received signal magnitude
8	Magnitude LSB	
9	Magnitude Exp.	
10	Ambient ADC	Relative ambient IR intensity
11	Precision MSB	Precision indication, small values correspond to small measurement errors
12	Precision LSB	
13	CRC MSB	CRC values of current data frame (Byte No.2 to No.12)
14	CRC LSB	

Note: Sensor will output a 65.53m over range indication if the measurement result is over ranged or receiving signal is too low.

The following is an example of the returned ranging data:

0x0A 0x0D 0x01 0x01 0x01 0x06 0xD9 0xFC 0x8C 0x02 0x01 0x00 0x01 0x9B 0x94

Decoding:

0x0A: Start byte

0x0D: Data length (13 byte data)

Distance = $(0x06 * 256 + 0xD9) / 1000.0f = 1.753$ (unit: m)

Magnitude = $((0xFC * 256 + 0x8C) \ll 0x02) / 10000.0f = 25.8608$

Ambient ADC = 1

Precision = $(0x00 * 256) + 0x01 = 1$

0x9B 0x94: CRC16-CCITT MSB and LSB byte

Command #4: Stop ranging

Table 12. Stop ranging command

Start byte	Command field	Data field						CRC MSB	CRC LSB
Byte 0	Byte 1	Byte 2	Byte 3	Byte 4	Byte 5	Byte 6	Byte 7	Byte 8	Byte 9
0x0A	0x30	0x01	0x00	0x00	0x00	0x00	0x00	0xBC	0x6F

Returned data:

Table 13. Returned data of stop ranging command

Byte No.	Name	Value	Description
0	Start byte	0x0A	Start byte of the returned data frame
1	Data length	0x03	Length of the data field, it does not include byte No.0 and byte No.1
2	ACK	0x01: Succeed; 0x00: Fail
3	CRC MSB	CRC values of current data frame (Byte No.2)
4	CRC LSB	

Command #5: Set offset compensation value

Due to the individual deviation of sensor performances, this command can be used to compensate the small offset deviation to achieve higher ranging precision. The offset values will be automatically saved to the internal non-volatile memory and reloaded with each power up.

Table 14. Set offset compensation value command

Start byte	Command field	Data field						CRC MSB	CRC LSB
Byte 0	Byte 1	Byte 2	Byte 3	Byte 4	Byte 5	Byte 6	Byte 7	Byte 8	Byte 9
0x0A	0x38	0x1A	Offset MSB	Offset LSB	0x00	0x00	0x00	Calculated CRC (Byte 0 to Byte 7)	

Offset = Actual distance – Sensor measured distance, unit: mm

Example:

Actual distance: 200mm, sensor measured distance: 215mm

Offset = 200 – 215 = -15 = 0xFFF1 (Offset MSB = 0xFF, Offset LSB = 0xF1)

Returned data:

Table 15. Returned data of set offset compensation value command

Byte No.	Name	Value	Description
0	Start byte	0x0A	Start byte of the returned data frame
1	Data length	0x03	Length of the data field, it does not include byte No.0 and byte No.1
2	ACK	0x01: Succeed; 0x00: Fail
3	CRC MSB	CRC values of current data frame (Byte No.2)
4	CRC LSB	

Command #6: Load configuration profiles

Table 16. Load configuration profiles command

Start byte	Command field	Data field						CRC MSB	CRC LSB
		Byte 2	Byte 3	Byte 4	Byte 5	Byte 6	Byte 7		
Byte 0	Byte 1	Byte 2	Byte 3	Byte 4	Byte 5	Byte 6	Byte 7	Byte 8	Byte 9
0x0A	0x3E	0x00: User profile 0xFF: Factory profile	0x00	0x00	0x00	0x00	0x00	Calculated CRC (Byte 0 to Byte 7)	

Returned data:

Table 17. Returned data of load configuration profiles command

Byte No.	Name	Value	Description
0	Start byte	0x0A	Start byte of the returned data frame
1	Data length	0x03	Length of the data field, it does not include byte No.0 and byte No.1
2	ACK	0x01: Succeed; 0x00: Fail
3	CRC MSB	CRC values of current data frame (Byte No.2)
4	CRC LSB	

Command #7: Set output filter strength

Increasing this value will improve the stability of output data but sacrifice some sensitivity. Decreasing this value makes the output data more sensitive to the distance change but sacrifice some stability. The default value is "0x000" and the setting values within ± 100 are recommended.

Table 18. Set output filter strength command

Start byte	Command field	Data field						CRC MSB	CRC LSB
		Byte 2	Byte 3	Byte 4	Byte 5	Byte 6	Byte 7		
Byte 0	Byte 1	Byte 2	Byte 3	Byte 4	Byte 5	Byte 6	Byte 7	Byte 8	Byte 9
0x0A	0x3D	0xAA	Filter MSB	Filter LSB	0x00	0x00	0x00	Calculated CRC (Byte 0 to Byte 7)	

Example:

Decrease the output stability by 50 units -> Filter value = -50 = 0xFFCE (Filter MSB = 0xFF, Filter LSB=0xCE)

Increase the output stability by 50 units -> Filter value = 50 = 0x0032 (Filter MSB = 0x00, Filter LSB=0x32)

Returned data:

Table 19. Returned data of set output filter strength command

Byte No.	Name	Value	Description
0	Start byte	0x0A	Start byte of the returned data frame
1	Data length	0x03	Length of the data field, it does not include byte No.0 and byte No.1
2	ACK	0x01: Succeed; 0x00: Fail
3	CRC MSB	CRC values of current data frame (Byte No.2)
4	CRC LSB	

Command #8: Acquire the analog frontend (AFE) temperature

Table 20. Acquire the analog frontend (AFE) temperature command

Start byte	Command field	Data field						CRC MSB	CRC LSB
Byte 0	Byte 1	Byte 2	Byte 3	Byte 4	Byte 5	Byte 6	Byte 7	Byte 8	Byte 9
0x0A	0x3F	0x01	0x00	0x00	0x00	0x00	0x00	0x36	0x86

Returned data:

Table 21. Returned data of acquire the analog frontend (AFE) temperature command

Byte No.	Name	Value	Description
0	Start byte	0x0A	Start byte of the returned data frame
1	Data length	0x04	Length of the data field, it does not include byte No.0 and byte No.1
2	AFE Temperature MSB	AFE Temperature = (MSB*256 + LSB) / 100, (Unit: Fahrenheit)
3	AFE Temperature LSB	
4	CRC MSB	CRC values of current data frame (Byte No.2 to No.3)
5	CRC LSB	

Ordering information

Hypersen product designator	HPS-	1	6	X	C	-	L
16x: ToF ranging sensor family							
None: 3.3V UART interface, without waterproof case							
U: 3.3V UART interface, with waterproof case							
C: 1Mbps CAN interface, with waterproof case							
None: 850nm LED (Light Emitting Diode) emitter							
L: 850nm VCSEL (Vertical Cavity Surface Emitting Laser) emitter							

Package information

Table 22. Package details

Model No.	HPS-167-L
Module dimensions	35(W) x 24(H) x 23(D) mm (Include lens cover)
Weight	8.8g / pcs (Include lens cover)
Tray	Modules of 50pcs. (10*5) per tray
Outer box	4 trays per box (module 200pcs)

Revision history

Table 23. Document revision history

Date	Revision	Description
24-February-2017	1.0	Initial release.
07-March-2017	1.1	Added CRC calculation description to command & returned data.
31-March-2017	1.2	Modified command #8 and returned data format.
11- February-2018	1.3	Added description of over range indication and ordering information.
19-April-2021	1.4	Modified the maximum range value.

Appendix

CRC16-CCITT C-language Implementations

Implementation 1:

```
#####
#include<stdio.h>
/**
Flash Space: Small
Calculation Speed: Slow
*/
/*Function Name:      crc_cal_by_bit      //Calculate CRC by bit
Function Parameters: unsigned char* ptr  //Pointer of data buffer
                   unsigned char len    //Length of data

Return Value:       unsigned int

Polynomial:        CRC-CCITT 0x1021
*/
unsigned int crc_cal_by_bit(unsigned char* ptr, unsigned char len)
{
#define CRC_CCITT 0x1021
unsigned int crc = 0xffff;

while(len-- != 0)
{
for(unsigned char i = 0x80; i != 0; i /= 2)
{
crc *= 2;
if((crc&0x10000) !=0)
crc ^= 0x11021;
if((*ptr&i) != 0)
crc ^= CRC_CCITT;
}
ptr++;
}
return crc;
}
#####
```

Implementation 2:

```
#####  
#include<stdio.h>  
/**  
Flash Space: Medium  
Calculation Speed: Medium  
*/  
/* Function Name:      crc_cal_by_halfbyte    //Calculate CRC by half byte  
   Function Parameters: unsigned char* ptr    //Pointer of data buffer  
                       unsigned char len     //Length of data  
  
   Return Value:      unsigned int  
   Polynomial:        CRC-CCITT 0x1021  
*/  
unsigned int crc_cal_by_halfbyte(unsigned char* ptr, unsigned char len)  
{  
    unsigned short crc = 0xffff;  
  
    while(len-- != 0)  
    {  
        unsigned char high = (unsigned char) (crc/4096);  
        crc <<= 4;  
        crc ^= crc_ta_4[high^(*ptr/16)];  
        high = (unsigned char) (crc/4096);  
        crc <<= 4;  
        crc ^= crc_ta_4[high^(*ptr&0x0f)];  
        ptr++;  
    }  
    return crc;  
}  
  
unsigned int crc_ta_4[16]={ /* CRC half byte table */  
    0x0000, 0x1021, 0x2042, 0x3063, 0x4084, 0x50a5, 0x60c6, 0x70e7,  
    0x8108, 0x9129, 0xa14a, 0xb16b, 0xc18c, 0xd1ad, 0xe1ce, 0xf1ef,  
};  
#####
```

Implementation 3:

#####

#include<stdio.h>

/**

Flash Space: Large

Calculation Speed: Fast

*/

```

/* Function Name:      crc_cal_by_byte      //Calculate CRC by byte
   Function Parameters: unsigned char* ptr  //Pointer of data buffer
                       unsigned char len   //Length of data

   Return Value:      unsigned int

   Polynomial:       CRC-CCITT 0x1021

```

*/

```

unsigned int crc_ta_8[256]={ /* CRC byte table */
    0x0000, 0x1021, 0x2042, 0x3063, 0x4084, 0x50a5, 0x60c6, 0x70e7,
    0x8108, 0x9129, 0xa14a, 0xb16b, 0xc18c, 0xd1ad, 0xe1ce, 0xf1ef,
    0x1231, 0x0210, 0x3273, 0x2252, 0x52b5, 0x4294, 0x72f7, 0x62d6,
    0x9339, 0x8318, 0xb37b, 0xa35a, 0xd3bd, 0xc39c, 0xf3ff, 0xe3de,
    0x2462, 0x3443, 0x0420, 0x1401, 0x64e6, 0x74c7, 0x44a4, 0x5485,
    0xa56a, 0xb54b, 0x8528, 0x9509, 0xe5ee, 0xf5cf, 0xc5ac, 0xd58d,
    0x3653, 0x2672, 0x1611, 0x0630, 0x76d7, 0x66f6, 0x5695, 0x46b4,
    0xb75b, 0xa77a, 0x9719, 0x8738, 0xf7df, 0xe7fe, 0xd79d, 0xc7bc,
    0x48c4, 0x58e5, 0x6886, 0x78a7, 0x0840, 0x1861, 0x2802, 0x3823,
    0xc9cc, 0xd9ed, 0xe98e, 0xf9af, 0x8948, 0x9969, 0xa90a, 0xb92b,
    0x5af5, 0x4ad4, 0x7ab7, 0x6a96, 0x1a71, 0x0a50, 0x3a33, 0x2a12,
    0xdbfd, 0xcbbc, 0xfbbf, 0xeb9e, 0x9b79, 0x8b58, 0xbb3b, 0xab1a,
    0x6ca6, 0x7c87, 0x4ce4, 0x5cc5, 0x2c22, 0x3c03, 0x0c60, 0x1c41,
    0xedae, 0xfd8f, 0xcdec, 0xddcd, 0xad2a, 0xbd0b, 0x8d68, 0x9d49,
    0x7e97, 0x6eb6, 0x5ed5, 0x4ef4, 0x3e13, 0x2e32, 0x1e51, 0x0e70,
    0xff9f, 0xefbe, 0xdfdd, 0xcffc, 0xbf1b, 0xaf3a, 0x9f59, 0x8f78,
    0x9188, 0x81a9, 0xb1ca, 0xa1eb, 0xd10c, 0xc12d, 0xf14e, 0xe16f,
    0x1080, 0x00a1, 0x30c2, 0x20e3, 0x5004, 0x4025, 0x7046, 0x6067,
    0x83b9, 0x9398, 0xa3fb, 0xb3da, 0xc33d, 0xd31c, 0xe37f, 0xf35e,
    0x02b1, 0x1290, 0x22f3, 0x32d2, 0x4235, 0x5214, 0x6277, 0x7256,
    0xb5ea, 0xa5cb, 0x95a8, 0x8589, 0xf56e, 0xe54f, 0xd52c, 0xc50d,
    0x34e2, 0x24c3, 0x14a0, 0x0481, 0x7466, 0x6447, 0x5424, 0x4405,
    0xa7db, 0xb7fa, 0x8799, 0x97b8, 0xe75f, 0xf77e, 0xc71d, 0xd73c,
    0x26d3, 0x36f2, 0x0691, 0x16b0, 0x6657, 0x7676, 0x4615, 0x5634,
    0xd94c, 0xc96d, 0xf90e, 0xe92f, 0x99c8, 0x89e9, 0xb98a, 0xa9ab,
    0x5844, 0x4865, 0x7806, 0x6827, 0x18c0, 0x08e1, 0x3882, 0x28a3,
    0xcb7d, 0xdb5c, 0xeb3f, 0xfb1e, 0x8bf9, 0x9bd8, 0xabbb, 0xbb9a,
    0x4a75, 0x5a54, 0x6a37, 0x7a16, 0x0af1, 0x1ad0, 0x2ab3, 0x3a92,
    0xfd2e, 0xed0f, 0xdd6c, 0xcd4d, 0xbdaa, 0xad8b, 0x9de8, 0x8dc9,
    0x7c26, 0x6c07, 0x5c64, 0x4c45, 0x3ca2, 0x2c83, 0x1ce0, 0x0cc1,
    0xef1f, 0xff3e, 0xcf5d, 0xdf7c, 0xaf9b, 0xbfba, 0x8fd9, 0x9ff8,

```

```
0x6e17, 0x7e36, 0x4e55, 0x5e74, 0x2e93, 0x3eb2, 0x0ed1, 0x1ef0
};
```

```
unsigned int crc_cal_by_byte(unsigned char* ptr, unsigned char len)
{
    unsigned short crc = 0xffff;

    while(len-- != 0)
    {
        unsigned int high = (unsigned int)(crc/256);
        crc <<= 8;
        crc ^= crc_ta_8[high^*ptr];
        ptr++;
    }

    return crc;
}
```

```
#####
```

Testing Code:

```
#####
```

```
void main()
{
    unsigned char sample_data[] = {0x01, 0x01, 0x01, 0x06, 0xd9, 0xfc, 0x8c, 0x02, 0x01, 0x00,
0x01}; //Result should be: 0x9b94
    unsigned char data1[] = {0x63}; //Result should be: 0xbd35
    unsigned char data2[] = {0x8c}; //Result should be: 0xb1f4
    unsigned char data3[] = {0x7d}; //Result should be: 0x4eca
    unsigned char data4[] = {0xaa, 0xbb, 0xcc}; //Result should be: 0x6cf6
    unsigned char data5[] = {0x00, 0x00, 0xaa, 0xbb, 0xcc}; //Result should be: 0xb166
    unsigned short r1 = 0, r2=0, r3=0, r4=0, r5=0, r_sample_data;

    //Implementation 1
    r1 = crc_cal_by_byte(data1, 1);
    r2 = crc_cal_by_byte(data2, 1);
    r3 = crc_cal_by_byte(data3, 1);
    r4 = crc_cal_by_byte(data4, 3);
    r5 = crc_cal_by_byte(data5, 5);
    r_sample_data = crc_cal_by_byte(sample_data, 11);
    printf("Implementation_1: r1= %x, r2=%x, r3=%x, r4=%x, r5=%x, r_sample_data=%x\n", r1, r2, r3,
r4, r5, r_sample_data);
    r1=r2=r3=r4=r5=0;
}
```

```

//Implementation 2
r1 = crc_cal_by_bit(data1, 1);
r2 = crc_cal_by_bit(data2, 1);
r3 = crc_cal_by_bit(data3, 1);
r4 = crc_cal_by_bit(data4, 3);
r5 = crc_cal_by_bit(data5, 5);
r_sample_data = crc_cal_by_bit(sample_data, 11);
printf("Implementation_2: r1= %x, r2=%x, r3=%x, r4=%x, r5=%x, r_sample_data=%x\n", r1, r2, r3,
r4, r5, r_sample_data);
r1=r2=r3=r4=r5=0;

//Implementation 3
r1 = crc_cal_by_halfbyte(data1, 1);
r2 = crc_cal_by_halfbyte(data2, 1);
r3 = crc_cal_by_halfbyte(data3, 1);
r4 = crc_cal_by_halfbyte(data4, 3);
r5 = crc_cal_by_halfbyte(data5, 5);
r_sample_data = crc_cal_by_halfbyte(sample_data, 11);
printf("Implementation_3: r1= %x, r2=%x, r3=%x, r4=%x, r5=%x, r_sample_data=%x\n", r1, r2, r3,
r4, r5, r_sample_data);
r1=r2=r3=r4=r5=0;
}
#####

```

IMPORTANT NOTICE – PLEASE READ CAREFULLY

Hypersen Technologies Co., Ltd. reserve the right to make changes, corrections, enhancements, modifications, and improvements to Hypersen products and/or to this document at any time without notice. Purchasers should obtain the latest relevant information on Hypersen products before placing orders. Hypersen products are sold pursuant to Hypersen's terms and conditions of sale in place at the time of order acknowledgement.

Purchasers are solely responsible for the choice, selection, and use of Hypersen products and Hypersen assumes no liability for application assistance or the design of Purchasers' products.

No license, express or implied, to any intellectual property right is granted by Hypersen herein.

Resale of Hypersen products with provisions different from the information set forth herein shall void any warranty granted by Hypersen for such product.

Hypersen and the Hypersen logo are trademarks of Hypersen. All other product or service names are the property of their respective owners.

Information in this document supersedes and replaces information previously supplied in any prior versions of this document.

© 2018 Hypersen Technologies Co., Ltd. – All rights reserved