

乐清市戴尔电子有限公司 YUEQING DAIER ELECTRON CO.,LTD		文件编号 FILE NO.	WS-M06-H
		发布日期 DATE OF ISSUE	2013年3月5日
规格书 SPECIFICATION		第 A 版 VERSION NO. A	第 1 页 共 7 页 Page one of seven
		产品系列 SERIES	轻触开关 TACT SWITCH

1、概述

1.1 适用范围

此规格书适用于机械式轻触开关的相关要求

1. 温度范围：

Temperature range:

1.1 保存的温度范围： -25℃~70℃

Storage Temperature range -25℃ to 70℃

1.2 使用的温度范围： -15℃~60℃

Temperature range for use -15℃ to 60℃

2. 测试环境条件：

Test circumstance condition:

环境温度： 16℃

Ambient temperature 16℃

相对湿度： 63%~74%

Relative humidity 63% to 74%

空气压力： 102 千帕

Air pressure 102KPa

3. 外观、结构和尺寸：

Appearance、 Structure and Dimension:

3.1 外观：

Appearance:

没有生锈，伤痕、电镀不良，破裂，剥离现象。动作正常，换位清晰。

Functionally free from rust, crack and bad plating.

3.2 结构和尺寸

Structure and Dimension:

参照有关外形图

Reference per attached outline drawing.

4. 额定值： DC 12 V 50mA

Rating: DC 12 V 50mA

乐清市戴尔电子有限公司 YUEQING DAIER ELECTRON CO.,LTD		文件编号 FILE NO.	WS-M06-H
		发布日期 DATE OF ISSUE	2013年3月5日
规格书 SPECIFICATION		第 A 版 VERSION NO. A	第 2 页 共 7 页 Page two of seven
产品系列 SERIES	轻触开关 TACT SWITCH	产品型号 TYPE	轻触系列
5. 机械性能: Mechanical performance:			
项目 Items		试验条件 Test conditions	规格 Requirements
5.1	按力 Press force	<p>开关垂直于操作方向放置，在驱动件顶端中心逐渐施力，测量开关导通所需的最大力度。</p> <p>Placing the switch such that the direction of switch operation is vertical, and then gradually increasing the load applied to the center of the knob the maximum load for the knob to come to a stop shall be measured.</p>	260gf ± 50gf
5.2	回弹力 Return force	<p>开关垂直于操作方向放置，驱动件顶端中心下降至全行程后，测量顶端向自由位置返回的力度。</p> <p>The sample switch is installed such that the direction of switch operation is vertical, and upon depression of knob in its center the whole travel distance, the force of the knob to return to its free position shall be measured.</p>	110 ± 30gf
5.3	行程 Travel	<p>开关垂直于操作方向放置，以一个等于 2 倍按力的静负荷施加于驱动件顶端中心，测量顶端的移动距离。</p> <p>Placing the switch such that the direction of switch operation is vertical and then applying a static load twice the operating force to the center of the knob, the travel distance for the knob to come to a stop shall be measured.</p>	0.3±0.15mm
5.4	驱动件强度 Actuator Strength	<p>在驱动件顶端面中央，施加 10 牛顿的力于按压方向的停止位上 5 秒。</p> <p>To the press direction 10N until the stop for 5 sec.</p>	<p>满足 5.1、6.1-6.3 项要求且操作元件不被损坏或太松。</p> <p>Item 5.1、6.1 to 6.3 shall be satisfied. Without damage of actuator. Function and action is in gear.</p>

乐清市戴尔电子有限公司 YUEQING DAIER ELECTRON CO.,LTD		文件编号 FILE NO.	WS-M06-H
		发布日期 DATE OF ISSUE	2013年3月5日
规格书 SPECIFICATION		第A版 VERSION NO. A	第3页 共7页 Page three of seven
产品系列 SERIES	轻触开关 TACT SWITCH	产品型号 TYPE	轻触系列
项目 Items	试验条件 Test conditions		规格 Requirements
5.5	接线端强度 Connection Port Strength	接线端任意方向施加 10 牛顿的力，持续时间： 10±1 秒。 To any the connection place pull 10N, 10±1sec.	接线端无损伤, 脱落; 功能动作正常 Without damage of connection Port function and action is in gear.
5.6	可焊性 Solder-Ability	蒸汽老化 1 小时后。端子的焊接部分浸入温度为 235±5℃熔融的焊锡内 2±0.5 秒。 An hour later, the steam ageing. The soldering area of the terminal shall be immersed into molten solder at a temperature of 235±5℃ for 2±0.5sec.	大于浸入部分的 90% 被焊锡覆盖。 More than 90% of the dipping part shall be covered by solder.
5.7	耐焊接热 Soldering heat resistance	端子的焊接部分浸入温度为 260±5℃熔融的焊锡 内 3±1 秒。 The soldering area of the terminal shall be immersed into molten solder at a temperature of 260±5℃ for 3±1 sec.	1) 不能出现变形 There shall not be deforming in appearance 2) 满足 5.1, 6.1 to 6.3 项要求 The requirements specified in Item 5.1, 6.1 to 6.3 shall be satisfie.
6. 电气性能: Electrical performance:			
6.1	接触电阻 Contact Resistance	电压: DC 5V Rating: DC 5V	电流: 100±2mA Current: 100±2mA
6.2	绝缘电阻 Insulation resistance	DC 100V. 1 分钟后进行测量 A voltage of 100V. DC shall be applied for 1 min after which measurement shall be made.	端子相互间 Between terminals
			每一端子和外壳间 Between individual terminal and frame
			100 兆欧以上 100MΩ or more

乐清市戴尔电子有限公司 YUEQING DAIER ELECTRON CO.,LTD		文件编号 FILE NO.	WS-M06-H	
		发布日期 DATE OF ISSUE	2013年3月5日	
规格书 SPECIFICATION		第A版 VERSION NO. A	第4页 共7页 Page four of seven	
产品系列 SERIES	轻触开关 TACT SWITCH	产品型号 TYPE	轻触系列	
项目 Items	试验条件 Test conditions		规格 Requirements	
6.3	耐压 Withstand Voltage	250V.AC/50HZ 1分钟 250V.AC/50Hz for 1 min,	应无闪弧及击穿现象。漏电流<0.5mA。 No arcing or break down shall occur. Trip current<0.5mA.	
		端子相互间 Between terminals 每一端子和外壳间 Between individual terminal and frame		
6.4	振动 Librate	振频 10-500Hz 振幅位移幅值: 0.35mm; 加速度幅值: 50m/s ² , 每次扫描时间: 11分钟。 共进行5次循环。 Librate frequency:10-500Hz Swing : Extent cost displacement should be 0.35mm; The accelerated extent cost should be 50m/s ² . The scan time:11 minutes once a time. Do it for five times.	应满足6.1项, 外观无明显异常, 功能动作应正常 Item 6.1 shall be satisfied, the facade of the switch have no abnormity , motion and function is good.	
7. 耐候性 Weatheralility				
7.1	恒定湿热 Invaria-Blenes Damp Heat	放置在温度为40±2℃, 相对湿度为90-95%的环境中96小时, 然后再放在标准大气环境中1小时, 在此后1小时内进行测量。 Switch for test shall be stored at a temperature 40±2℃, and a relative humidity of 90-95% for 96 hours. Then the switch shall be maintained at standard atmospheric conditions for an hour after which measurement shall be made within 96hour.	接触电阻. 参照6.1 Contact resistance. Refer to Item 6.1	100毫欧以下 100mΩ or less
			绝缘电阻. 参照6.2 Insulation resistance. Refer to Item 6.2	10兆欧以上 10MΩ or more
			耐电压. 参照6.3 Withstand voltage. Refer to Item 6.3	应无闪弧及击穿现象 No arcing or break down Shall occur.
			操作力和外观 Operating force and appearance	满足第5.1中的要求, 塑件没有出现变形或裂纹, 没有出现严重变色及生锈。 Item 5.1 shall be satisfied , there shall be no deformation or cracks in molded part or excessive rust and discoloration.

乐清市戴尔电子有限公司 YUEQING DAIER ELECTRON CO.,LTD		文件编号 FILE NO.	WS-M06-H	
		发布日期 DATE OF ISSUE	2013年3月5日	
规格书 SPECIFICATION		第A版 VERSION NO. A	第5页 共7页 Page five of seven	
产品系列 SERIES	轻触开关 TACT SWITCH	产品型号 TYPE	轻触系列	
项目 Items	试验条件 Test conditions		规格 Requirements	
7.2	高温 Dry heat proof	储放在 70±2℃ 的温箱中 72 小时后, 在标准大气环境中放置 1 小时, 然后在 1 小时之内测量。 Switch for test shall be stored at a temperature of 70±2℃ for 72 hours, and at standard atmospheric Conditions for 1hour then to be measured within an hour.	满足第 3.1, 5.1, 6.1 至 6.3 中的要求 The Item 3.1, 5.1, 6.1 to 6.3 shall be satisfied.	
7.3	低温 Cold Proof	储放在 -25±3℃ 的冰箱中 16 小时后, 在标准大气环境中放置 1 小时, 然后在 1 小时之内测量。 Switch for test shall be stored at a temperature of -25±3℃ for 16 hours, and at standard atmospheric conditions for 1hour then to be measured within 1 hour.		
7.4	防护等级 Degree of protection	符合 GB4208-93 IP64 要求 Accord with GB4208-93 IP 64 Requirement		
8. 耐久性能 Durability				
8.1	寿命试验 Life Test	100,000 cycles of a knob operation shall be performed continuously at a rate of 2~3 cycles/sec. 操作元件以每秒钟 2~3 次的速度连续完成 100,000 次动作。	按力. 参照 5.1 Press force. Refer to Item 5.1	初始力度值±30% ±30% of initial force
			接触电阻. 参照 6.1 Contact resistance. Refer to Item 6.1	100 毫欧以下 100 mΩ or less
			绝缘电阻. 参照 6.2 Insulation resistance. Refer to Item 6.2	10 兆欧以上 10 MΩ or more
			耐电压. 参照 6.3 Withstand voltage. Refer to Item 6.3	应无闪弧及击穿 No arcing or Break down shall occur.

乐清市戴尔电子有限公司 YUEQING DAIER ELECTRON CO.,LTD		文件编号 FILE NO.	WS-M06-H
		发布日期 DATE OF ISSUE	2013年3月5日
规格书 SPECIFICATION		第 A 版 VERSION NO. A	第 6 页 共 7 页 Page six of seven
		产品系列 SERIES	轻触开关 TACT SWITCH
9. 焊接条件: Soldering conditions:			
项目 Items		推荐条件 Recommended conditions	
9.1	手工焊接 Hand soldering	请按以下条件进行焊接: (1) 焊锡温度: $\leq 330^{\circ}\text{C}$ (2) 连续焊接时间: $\leq 3\text{ s}$ (3) 电烙铁的功率: $\leq 20\text{ W}$ Please practice according to below conditions: (1) Soldering temperature: 330°C Max. (2) Continuous soldering time: 3 s Max. (3) Capacity of soldering iron : 20 W Max.	
9.2	自动焊接 Automatic flow soldering	(1) 预热: 在 PWB 进入焊接装置后, 在 2 ± 0.3 分钟内铜箔表面的温度应达到预热的最高温度 180°C ; (2) 焊接: 在 PWB 进入焊接热区域后, 最长 10 秒内铜箔表面的温度应达到 260°C 的峰值温度; (3) 说明: 以上提及的条件是零部件上 PWB 表面的温度, 由于 PWB 的材料, 尺寸、厚度等不同 PWB 从开关表面获得的温度也会有很大的不同, 因此, 千万小心不要让开关表面的温度超过 280°C 。 (1) Preheat: Temperature on the copper foil surface should reach preheat maximum temperature of 180°C within $2\text{min} \pm 0.3\text{min}$. after the PWB entered into the soldering equipment. (2) Soldering: Temperature on the copper foil surface should reach the peak temperature of 260°C within 10 seconds max. after the PWB entered into soldering heat zone. (3) Caution: The condition mentioned above is a temperature on the PWB surface on which parts are mounted. There are cases where PWB temperature greatly differs from switch's surface temperature depending on PWB material , size , thickness , etc . Care , therefore , should be used not to allow switch's surface temperature to exceed 280°C .	

乐清市戴尔电子有限公司
EQING DAIER ELECTRON CO.,LTD

文件编号
FILE NO.

WS-M06-H

发布日期
DATE OF ISSUE

2013年3月5日

规格书
SPECIFICATION

第A版
VERSION NO. A

第7页 共7页
Page seven of seven

产品系列
SERIES

轻触开关
TACT SWITCH

产品型号
TYPE

轻触系列

尺寸外型图

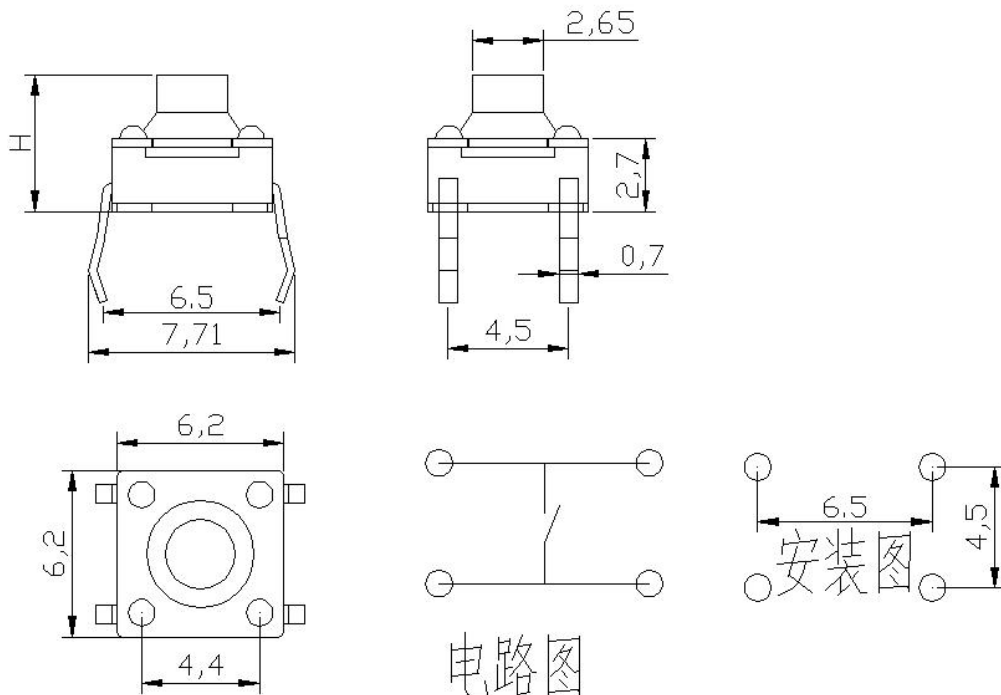

技术要求:

- 1、此产品技术要求详见《产品规格书》。
- 2、未注公差： $\pm 0.3\text{mm}$ ；H代表高度， $H = 4.3、5 \pm 0.1\text{mm}$ ；
- 3、环保要求：符合 ROHS 标准。

序号	部件名称	图号	材料	材料规格及牌号	数量	备注
1	接线片	KANF0605	高精铜	H65Y 1-0.3	1	镀银
2	基座	KANF0605	增强尼龙	PA66	1	黑色
3	簧片	KANF0605	不锈钢覆银	F. Ag STS301	1	覆银
4	盖板	KANF0605	高精铜	H65Y 1-0.2	1	镀镍
5	手柄	KANF0605	增强尼龙	PA66	1	红色
6	防尘膜	KANF0605	天然橡胶	FX-580	1	黑色
7	防水膜	KANF0606	聚酰亚胺胶带	FX-830	1	黄色